

**SAGE THERMAL GAS MASS FLOW METER**  
**User Manual**

**For SAGE RIO Models SIX and SRX**  
**Certified for Hazardous Service**

DOCUMENT NUMBER 100-0162  
REVISION 11 - SIX/SRX (SAGE RIO)

**Make the Wise Choice.**  
**Choose Sage Flow Meters.**



**SAGE METERING, INC.**  
8 Harris Court, D1  
Monterey, CA 93940  
1-866-677-SAGE (7243)  
Tel 831-242-2030  
Fax 831-655-4965  
[www.sagemetering.com](http://www.sagemetering.com)



## Table of Contents

<b>Introduction</b>	Welcome . . . . .	5
<b>SECTION A</b>	<b>Unpacking Your Sage Meter . . . . .</b>	<b>9</b>
<b>Getting Started</b>	Maintenance . . . . .	9
	Calibration . . . . .	9
	Installation and Mounting . . . . .	10
	Locating Proper Wiring Diagram . . . . .	10
	Insertion Flow Meter Application. . . . .	11
	Sage Valve Assembly Operation . . . . .	11
	Compression Fitting Operation . . . . .	12
	Installation Instructions . . . . .	12
	Captive Flow Conditioners . . . . .	13
	Probe Insertion Guideline Drawing . . . . .	14
	Installation Depth Chart . . . . .	15
	Configuration for Utilizing Four Flow Meters for Large Round Pipes. . . . .	16
	In-line Flow Meter Application . . . . .	17
	Electrical Wiring . . . . .	18
	Output Wiring. . . . .	19
	Internally Powered 4-20 mA and Pulse . . . . .	20
	Remote Cable Wiring . . . . .	21
<b>SECTION B</b>	<b>Principle of Operation . . . . .</b>	<b>25</b>
<b>Styles and Features</b>	Features and Benefits . . . . .	26
	Sage Rio Styles & Specifications . . . . .	27
	Sage Rio Organic (OLED) Display. . . . .	28
	Hazardous Location Approvals. . . . .	29
	Declaration of Conformity Certificate . . . . .	30
	SIX Series Integral Style Flow Meters . . . . .	31
	SRX Series Remote Style Flow Meters . . . . .	32
	Remote Bracket Layout . . . . .	33
	Mounting Hardware:	
	SVA05 Series Isolation Valve Assembly for Insertion Meters . . . . .	34
	STCF Series Teflon Ferrule Compression Fitting . . . . .	34
	SVA05 Series Isolation Valve Assembly Detail. . . . .	34
	Mounting Plate for Thin Walled Ducts . . . . .	34
	SVA05LP Low Pressure Isolation Valve Assembly. . . . .	35
	In-Line and Insertion Flanges. . . . .	36

*continued on next page*

<b>SECTION C</b>	Common Diagnostics . . . . .	39
<b>Diagnostics</b>	In-Situ Calibration Check . . . . .	42
<b>SECTION D</b>	Limited Warranty . . . . .	45
<b>Warranties and Service Work</b>	Cancellation/Return Policy . . . . .	45
	Returning Your Sage Flow Meter . . . . .	47
	Return Material Authorization Form . . . . .	48
<b>SECTION E</b>	Modbus Register Listing . . . . .	51
<b>Modbus</b>	Modbus Protocol & Function Codes . . . . .	52
	Sage Register Output Format . . . . .	57
	Sage Addresser Software . . . . .	57
	Sage Addresser Typical Printout (Version 3.14) . . . . .	58
<b>SECTION F</b>	HART . . . . .	61
<b>HART</b>	Wiring Instructions:	
<b>(optional)</b>	DC Input Power Wiring . . . . .	62
	AC Input Power Wiring . . . . .	62
	HART Menu Tree . . . . .	63
	HART Details . . . . .	65
<b>SECTION G</b>	Sage Rio Service Department “Dongle” . . . . .	71
<b>Appendix</b>	Correction Factors For Varying Gas Mixes . . . . .	72
	Installations Where Pipe Condensation May Develop . . . . .	72
	J-Box and Upstream Orientation . . . . .	73
	What Is a Thermal Mass Flow Meter? . . . . .	74

## Welcome

We are pleased that you have purchased a Sage Metering Mass Flow Meter for your requirement. We hope that you are satisfied with the performance, operation and design of our highly precise, NIST traceable Thermal Gas Mass Flow Meter.

Sage Metering is your source for monitoring, measuring and controlling the gas mass flow in your industrial process, building management system or environmental application. Our high performance, NIST Traceable, Thermal Mass Flow Meters will help increase productivity, reduce energy costs, maximize product yields, and/ or help reduce environmental insult. Sage provides high quality In-Line and Insertion Thermal Mass Flow Meters for a wide variety of industrial, commercial, and environmental monitoring needs, including carbon credit verification for Greenhouse Gas reduction.

Sage Meters measure mass flow directly — there is no need for ancillary instrumentation such as temperature or pressure transmitters. Furthermore, our instruments have exceptional signal sensitivity, have no moving parts, require little if any maintenance, have negligible pressure drop and have a turndown up to 100 to 1, and resolve as much as 1000 to 1. Sage Flow Meters can measure the mass flow rate and consumption of air, oxygen, natural gas, nitrogen, digester gas, biogas, flare gas, hydrogen, argon, carbon dioxide and other gases and gas mixes.

Sage Rio is the latest addition to our family of high performance Thermal Mass Flow Meters. It features a bright graphical display of Flow Rate, Total and Temperature, robust industrial enclosure, and easy to access power and output terminals. Sage Rio has a dual-compartment windowed enclosure featuring a very high contrast photo-emissive OLED display. The rear compartment, which is separated from the electronics, has large, easy to access and well marked terminals, for ease of customer wiring. It is powered by 24 VDC (12 VDC optional, or 115/230 VAC). The power dissipation is under 2.5 watts (e.g. under 100 mA at 24 VDC for the DC version.)

Please let us know if we can assist you in any way with your Sage Meter, or if you have any questions about its installation, operation, or features. Simply phone us at 866-677-SAGE (7243), or visit our website at [www.sagemetering.com](http://www.sagemetering.com) to contact a factory representative in your area. This manual is available on the website under Knowledge Base section.

Sincerely,



Robert Steinberg  
*President*



# Section

**A**

**GETTING STARTED**



## Getting Started

### UNPACKING YOUR SAGE METER

Your Sage flow meter is a sensitive, yet rugged, precision built electronic instrument. Upon delivery, care should be taken when opening the shipping container and removing your meter. The meter should be inspected for any damage that may have occurred during transit. If damage is found, please contact the carrier immediately to place a claim for damaged goods. The contents of the container should be checked against the packing list for any discrepancies. If there are any questions as to the contents or configuration of the equipment including calibration ranges, or, mounting hardware, contact Sage Metering as soon as possible. Please save shipping container and packaging materials (including PVC tube probe protector on Sage Insertion Flow Meters) in case the unit needs to be returned for any reason.

### MAINTENANCE

Sage thermal mass flow meters essentially require little or no maintenance. While the sensing element is somewhat resistant to dirt and particulate build up, it may become necessary to clean it from time to time if mounted in extremely dirty environments. NOTE: ALWAYS REMOVE THE POWER PRIOR TO ANY CLEANING OR MAINTENANCE. A detergent or appropriate non-corrosive solvent for removing the

buildup may be required. A soft brush can be used to gently clean the sensing element's surface, using caution to avoid damaging the sensor elements (the RTDs). If any disassembly is necessary, contact Sage Metering, Inc. for instructions. **In general, it is recommended that your Sage Thermal Mass Flow Meter be returned to the factory if cleaning, repair, or recalibration is needed. This is usually the most cost-effective and reliable alternative.**

### CALIBRATION

Sage Rio has continuous diagnostics. The raw calibration milliwatts (mw) is always displayed in the upper left hand corner of the meter's display. At any time, you can check this reading at a "no flow" condition and compare the reading to the original reported "zero flow" value noted on the last few lines of your meter's Certificate of Conformance or the flow meter's data tag. This diagnostic procedure not only checks the sensor performance and the "live zero" calibration point, but it verifies that the sensor is clean. It essentially provides a means to validate the meter's performance, verifies that there is no shift or drift, and eliminates the need for annual factory calibrations. This simple field diagnostic procedure also verifies that the sensor is free from contamination, even without inspection. See "In-Situ Calibration Check" on page 42.



**CAUTION** If installing in a Class I hazardous location the installation must comply with appropriate electrical codes.



**CAUTION** Installer must supply proper ground and bond wire for the transmitter and the sensor per appropriate electrical codes



**Cable entries must be used which maintain the ingress protection of the enclosure to at least IP66.**



**Unused cable entries must be filled with suitable blanking plugs which maintain the ingress protection of the enclosure to at least IP66.**

## INSTALLATION AND MOUNTING

### The EN 60079-14 must be considered

- Check the Certificate of Conformance included with your Sage Thermal Mass Flow Meter for system pressure, temperature, gas composition, power input, and signal output.
- It is recommended that the flow meter be inserted in a location of maximum straight run. It is suggested that there be a minimum of 15 pipe diameters of straight run upstream, and 5 diameters downstream, depending on the conditions. See chart on page 11. Note, obstructions such as valves, blowers, expanders and PVC and HDPE pipes will require additional straight run (contact factory for assistance).
- Check the orientation<sup>1</sup>: Standard calibration flow direction is left to right when facing the flow meter. Gas flow direction is marked with an arrow on in-line flow meters; UPSTREAM is marked on insertion probes.
- Do not rotate probe<sup>1</sup>, or errors may occur. If enclosure is facing incorrectly, rotate the enclosure 180°, but do not rotate the probe. The UPSTREAM mark still needs to be facing Upstream.
- Hook up the system per the wiring diagram provided with your Sage flow meter (see inside of rear compartment cover for terminal designation). Double check that wiring for the proper power and signal connections are correct.
- Check that all plumbing and electrical hook-ups are in accordance with OSHA, NFPA, and all other safety requirements.
- For Remote Style Meters (SRX) be sure the Remote Electronics is matched with the Transmitter's Junction Box and its attached Probe or Flow Body. There will be Metal Serial Number Tags on both the Transmitter as well as the Remote Electronics enclosure. Do not mismatch the serial numbers of the Remote Electronics and the Junction Box, or calibration errors will occur.**

## LOCATING PROPER WIRING DIAGRAM

Electrical wiring diagrams are found on pages 18–21. Units with “HART” in the model number should also refer to page 62.

## WIRING

Follow the instructions below to remove the rear cap for wiring. CAUTION: Do not open the display side!

Before removing the rear cap to access the wiring terminals it is essential to loosen the set screw used to lock down the cap. After the wiring is completed (see pages 18 to 21 for wiring details or pages 62 for HART), please close the lid, and re-tighten the set screw in the same manner.

The intended use of the SIX/SRX is for industrial applications in hazardous atmospheres of up to zone 1: gas, vapors, and mists. *Note: See page 29 for Hazardous Location Approvals.*

Customer repair of the product (or replacement of components) is not allowed. If the equipment is used in a manner not specified by the manufacturer, the protection provided by the equipment may be impaired. Permanently connected equipment shall employ a switch or circuit breaker as a means for disconnection in the installment.

<sup>1</sup> The Integral Style of Sage Rio Insertion Meters have the Display oriented as shown on page 14. If an alternate orientation of the display, or enclosure is required (ie. installation into a vertical pipe), please furnish a sketch or drawing, and specify “ROTATE” on purchase order. However, if it is later determined that the enclosure needs to be rotated, that procedure can be done in the field. However, if the display needs to be rotated, then the meter must be sent back to Sage to be modified. Do not attempt this in the field. An RMA will be required prior to returning the meter (see page 48). The procedure for rotating the enclosure is as follows: Clamp the enclosure of the Rio in a vise with the probe pointing up to the ceiling. Then take a 7/8 wrench and turn the probe to the proper orientation. Lock the probe into its new position with a set screw (not provided).

## Insertion Flow Meter Application

### FLOW PROFILE AND INSTALLATION CONSIDERATIONS

Insertion Flow Meters, although generally easier to install than In-Line Flow Meters, require proper installation, and a well developed flow profile, in order to perform properly. Please refer to the section on the following pages titled PROBE INSERTION GUIDELINE DRAWING (page 14) and INSTALLATION DEPTH CHART (page 15).

### SAGE VALVE ASSEMBLY OPERATION

Valve assemblies (SVA05 and SVA05LP) are an optional mounting hardware for Insertion Style Flow Meters (see pages 34 and 35). They allow the removal of insertion-style meters for service, cleaning, recalibration, relocation, etc. without the need to “shut-down” your process. The probe insertion depth is adjustable to permit sensor to be located at center to optimize measurement accuracy. (Refer to PROBE INSERTION GUIDELINE DRAWING and CHART, pages 14 & 15.) The ball valve will seal off leaks of the process gas at the point of insertion after the probe assembly has been removed. The assembly includes a valve, threadolet, compression fitting with Teflon ferrule, a cable restraint, and two collar clamps.

A threaded half coupling (3/4" FNPT) properly sized to accommodate the isolation valve retractor assembly must be fitted to the pipe/duct to which the

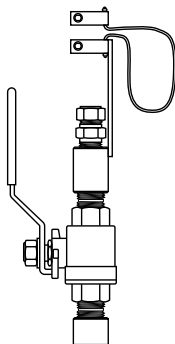

**NOTE:**  
Detailed Drawings are shown on pages 34 & 35.

insertion probe will be inserted. **Avoid T-Fittings since they will disturb the flow profile, and effectively reduce the measurement area.** Direct threading together (or with necessary bushings) of the retractor assembly may be required. In other cases, the threadolet must be welded in place and a clearance hole must be drilled through the pipe/ duct to accept the probe assembly. **If the pipe/duct is under pressure during installation, a hot tap drill (not available through Sage Metering) may be required.**

### FLOW CONDITIONING AND STRAIGHT RUN

Although a minimum of 15 pipe diameters of upstream straight run is commonly recommended, to absolutely assure that the flow profile is well developed at the point of measurement, either use Flow Conditioners (standard in Sage In-Line Flow Meters, 1/2" and larger, and also available as assemblies for Insertion Flow Meters, see page 13), or consider additional straight run. The Chart below provides examples of the amount of straight run that would virtually assure that there are no flow disturbances at the point of measurement.

IMPORTANCE OF FLOW CONDITIONING Recommended Pipe Diameters Upstream			
DISTURBANCE	WITHOUT FLOW CONDITIONING	WITHOUT FLOW CONDITIONING	WITH FLOW CONDITIONING <sup>1</sup>
	Sage Recommendation	Minimum Industry Recommendation	Sage Recommendation
One 90° Elbow	25	15	3
Two 90° Elbows in the same plane	36	20	5
Two 90° Elbows in different planes	62	At least 40	9
4:1 Area Reduction	18	15	3
4:1 Area Expansion	84	At least 30	10
Multiple Disturbance	TBD	TBD	TBD

<sup>1</sup> This column applies to In-Line Flow Meters, which come standard with built-in Flow Conditioners, as well as Insertion Meters, when provided with upstream Captive Flow Conditioners (see page 13).

## COMPRESSION FITTING OPERATION

A bored through tube fitting, properly sized to accommodate an insertion probe's particular OD, can be provided by the user or purchased as an option from Sage Metering (see page 36). Prior to installation, a clearance hole to accommodate the insertion probe assembly must be drilled in the pipe/duct. A fitting (1/2" FNPT) is then welded in place or threaded into the half-threadolet which has been welded to the pipe/duct. The probe insertion depth is adjustable to permit sensor to be located at center, to optimize measurement accuracy. (Refer to PROBE INSERTION GUIDELINE DRAWING and CHART, pages 14 & 15.)

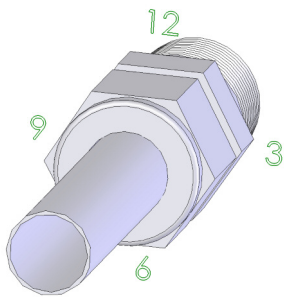

Insert the probe shaft tubing into the compression fitting to the position indicated in the Probe Insertion guidelines.

## INSTALLATION INSTRUCTIONS

1. Insert tubing into the tube fitting.
2. Make sure that the tubing is positioned properly per the PROBE INSERTION GUIDELINE DRAWING AND CHART, pages 14 & 15.
3. **Due to the variations of tubing diameters, a common starting point is desirable. Therefore, tighten the nut until the tubing will not turn by hand or move axially in the fitting.**
4. Scribe the nut at the 6 o'clock position.
5. While holding fitting body steady, tighten the nut 1¼ turns to the 9 o'clock position.

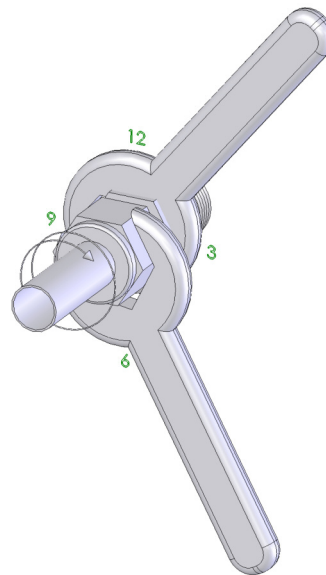

While holding the fitting body steady, tighten the nut one and one-quarter turns to the 9 o'clock position.

**CAPTIVE FLOW CONDITIONERS  
Can Be Installed in Conjunction with Insertion Style Flow Meters**

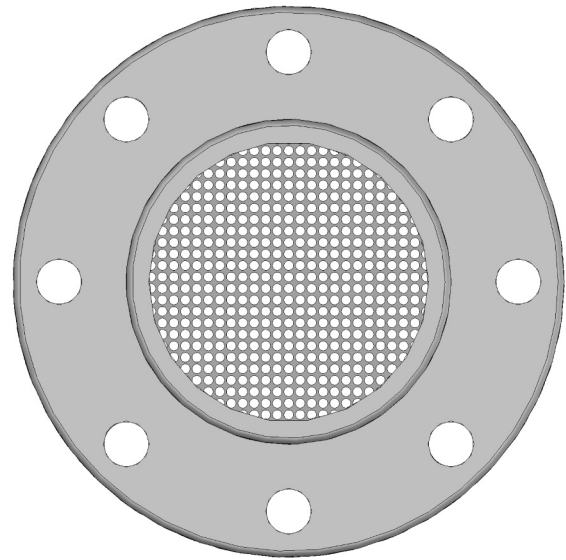
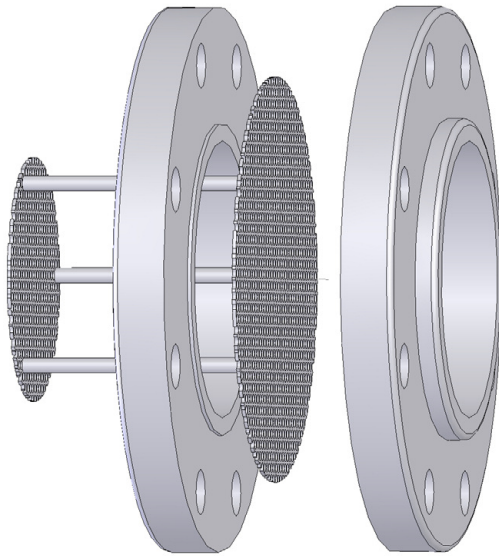

Front View of one of the Conditioning Plates

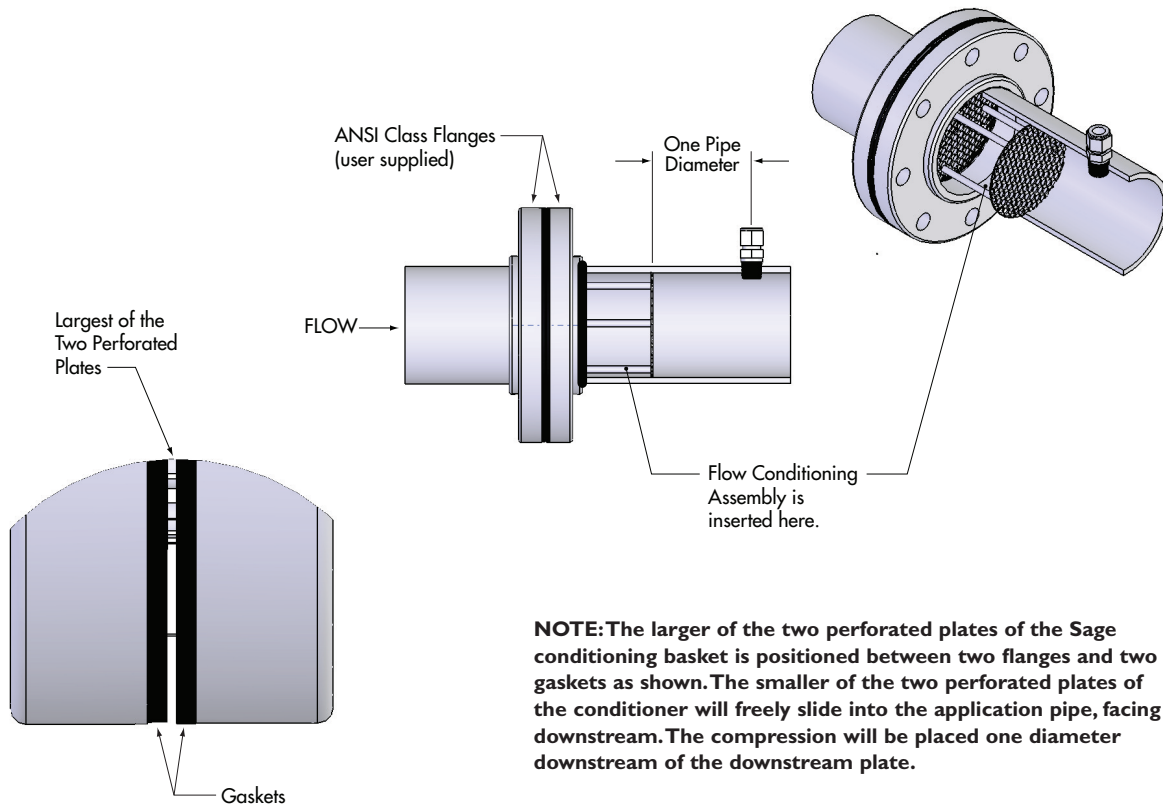

**NOTE:** The larger of the two perforated plates of the Sage conditioning basket is positioned between two flanges and two gaskets as shown. The smaller of the two perforated plates of the conditioner will freely slide into the application pipe, facing downstream. The compression will be placed one diameter downstream of the downstream plate.

### PROBE INSERTION GUIDELINE DRAWING<sup>1</sup>

Choose the longest straight-run section of pipe available to allow a uniform, well-developed flow profile. Allow for a **minimum** of 15 pipe diameters of straight run upstream, and 5 diameters downstream, depending on the conditions. See chart on page 11. Note, obstructions such as valves, blowers expanders and PVC and HDPE pipes will require additional straight run (contact factory for assistance). Avoid, if possible, installations immediately downstream of bends, fans, nozzles, heaters and especially valves, or anything else installed in the line that may cause nonuniform flow profiles and swirls. Otherwise signal output errors could result, unless significantly more straight run is provided, or in the absence of sufficient straight run, Flow Conditioners (page 13) are installed (contact Sage for assistance if needed). Refer to page 13 to see the benefits of incorporating Flow Conditioners.

Insertion styles are available through Sage Metering, Inc. with a standard 1/2" OD probe support assembly. Standard probe lengths are 6", 12", 15", 18", 24", 30" and 36". A common method of mounting the probe assembly through a pipe wall or duct (if ambient air) is with a compression fitting (STCF05). A Sage valve assembly (SVA05) is useful and highly recommended for pressurized applications or other gases, such as Natural Gas. Flange mounting is optionally available.

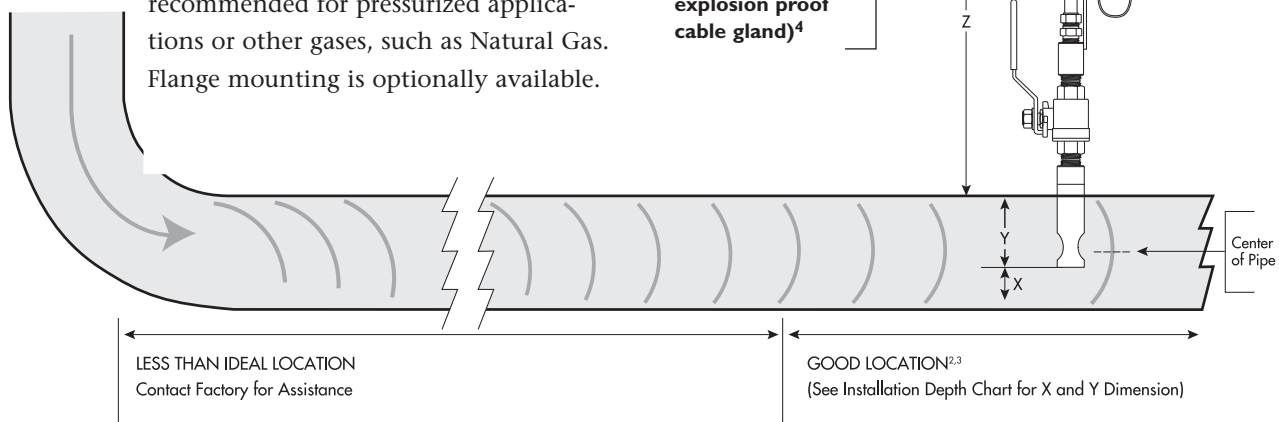

Sage insertion style flow meters can be assembled and calibrated for use in virtually any size pipe or duct (as small as 1"). Sage insertion flow meters include a probe assembly that supports the sensing element (a self-heated flow sensor and a temperature/reference sensor); a sensor drive circuit; micro-processor meter board, and transmitter enclosure. The probe assembly must be inserted into the correct position in the process gas flow conduit to allow the gas to flow through the sensor "window" across the sensor element. The "sensing point" or active part of the sensor (0.5" from the end of the probe) should be positioned as per the drawing below and the Installation Depth Chart on page 15.

### Installation Depth

The center of the pipe (assuming a well developed turbulent flow profile) is fairly flat, and easy to locate. See "Installation Depth Chart" on next page to determine proper insertion depth.

1. SIX Industrial Meter shown in drawing. Note, probe is not bi-directional.
2. Probe should be inserted per Installation Depth Chart (see following page), so sensors are in the center of the pipe.
3. The portion of the probe that remains outside of the pipe, is simply the factory ordered probe length (i.e. "15" = 15 inches) minus the "Y" dimension.
4. CAUTION: End user shall provide an ATEX, Zone I approved cable.

**INSTALLATION DEPTH CHART**

**Methods for Probe Insertion to Pipe Center**

**METHOD 1**

Using charts below, select pipe size (column 1), determine X. Insert probe until the end touches the bottom of the pipe (ID), mark probe as it exits top of fitting. Lift probe distance "X" and tighten compression fitting.

**METHOD 2**

Using charts below<sup>1</sup>, select pipe size (column 1), determine Y. Subtract Y from the factory supplied probe length. That difference Z (see drawing on page 14) should be outside of the pipe, and is measured from the bottom of the enclosure at the probe weld to pipe OD.

- 1 For other Pipe Schedules, such as Schedule 10, contact Sage, however the Y dimension will be the same for any Schedule Pipe
- 2 The 1" Pipe Size needs to have the Probe "Bottomed Out" (option "BOT"); the calibration method for the 1½" Pipe is either as shown below, or with option "BOT"

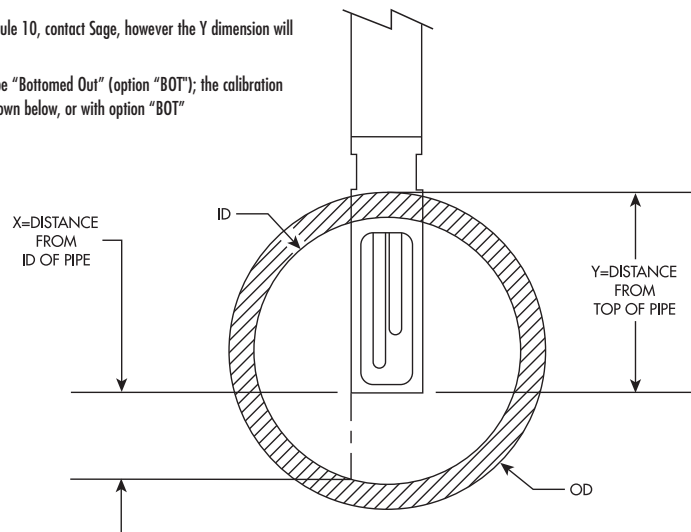

SCHEDULE 40 PIPE <sup>2</sup>					
PIPE SIZE	OD	ID	X	Y	PIPE AREA
1"	C O N S U L T F A C T O R Y				
1.5"	1.900	1.610	.20"	1.56"	0.0141
2"	2.375	2.067	.40"	1.82"	0.0233
2.5"	2.875	2.469	.60"	2.07"	0.0332
3"	3.500	3.068	.90"	2.38"	0.0513
4"	4.500	4.026	1.40"	2.86"	0.0884
6"	6.625	6.065	2.40"	3.95"	0.2006
8"	8.625	7.981	3.40"	4.90"	0.3474
10"	10.750	10.020	4.40"	6.00"	0.5476
12"	12.750	11.938	5.50"	7.00"	0.7773
14"	14.000	13.124	6.00"	7.50"	0.9394
16"	16.000	15.000	7.00"	8.60"	1.2272
18"	18.000	16.876	8.00"	9.60"	1.5533
24"	24.000	22.625	10.75"	12.60"	2.7919

SCHEDULE 80 PIPE <sup>2</sup>					
PIPE SIZE	OD	ID	X	Y	PIPE AREA
1"	C O N S U L T F A C T O R Y				
1.5"	1.900	1.500	.15"	1.56"	0.0123
2"	2.375	1.939	.35"	1.82"	0.0205
2.5"	2.875	2.323	.55"	2.07"	0.0294
3"	3.500	2.900	.80"	2.38"	0.0459
4"	4.500	3.826	1.30"	2.86"	0.0798
6"	6.625	5.761	2.25"	3.95"	0.1810
8"	8.625	7.625	3.25"	4.90"	0.3171
10"	10.750	9.750	4.25"	6.00"	0.5185
12"	12.750	11.374	5.13"	7.00"	0.7056
14"	14.000	12.500	5.70"	7.50"	0.8522
16"	16.000	14.312	6.60"	8.60"	1.1172
18"	18.000	16.124	7.50"	9.60"	1.4180
24"	24.000	21.562	10.25"	12.60"	2.5357

**CONFIGURATION FOR UTILIZING FOUR (4) SAGE INSERTION MASS FLOW METERS FOR LARGE ROUND PIPES OR DUCTS LARGER THAN 36" TO MINIMIZE EFFECTS OF VARYING FLOW PROFILES  
(It is recommended that Factory be contacted to assist with applications of this nature)**

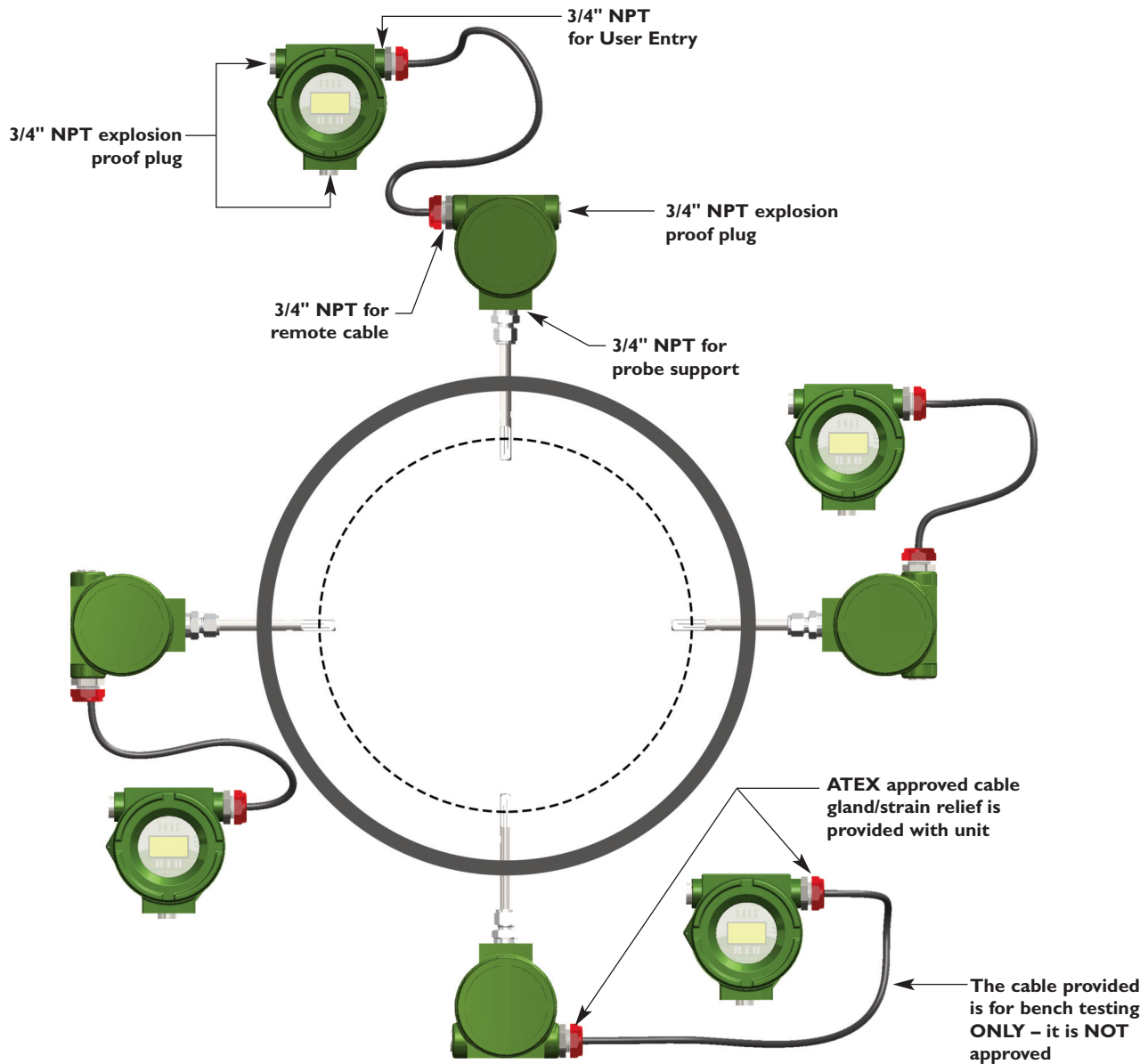

The outputs of the four meters will be averaged by customer's PLC or other method to improve overall accuracy in measuring the flow rate. (For medium sized round pipes [18" to 36"], two meters,

on the opposite side of the same diameter, may be sufficient [insert parallel to an upstream 90 degree bend for optimal benefit.]) Note, in this configuration, all sensors need to be averaged.

## In-Line Flow Meter Application

### IN-LINE FLOW METERS

In-line mounting styles are available through Sage Metering, Inc. in sizes from 1/4" pipe through 4" pipe. Threaded male NPT ends are standard up to 2-1/2"; ANSI 150lb flanged ends are recommended for 3" and 4" models. Contact the factory if optional end mounting styles are required. Pipe sizes in excess of 4" require the insertion style mass flow meter.

The in-line style flow meter assembly flow section is typically specified to match the user's flow conduit and is plumbed directly in the flow line by thread-

ing, flanging, welding, etc. **DO NOT USE REDUCERS.** It includes the sensing element (a self-heated flow sensor and a temperature/reference sensor) mounted directly in the specified flow section for exposure to the process gas; a sensor drive circuit; microprocessor meter board, and transmitter enclosure.

All in-line Flow Meters, 1/2" and up have built-in Flow Conditioners. See Table (page 11) for Upstream Straight run requirements. **Note**, the 1/4" and 3/8" do not have Flow Conditioners and thus require more straight run.

### FLOW CONDITIONING SCREENS FOR IN-LINE FLOW BODIES 1/2" AND UP<sup>1</sup>

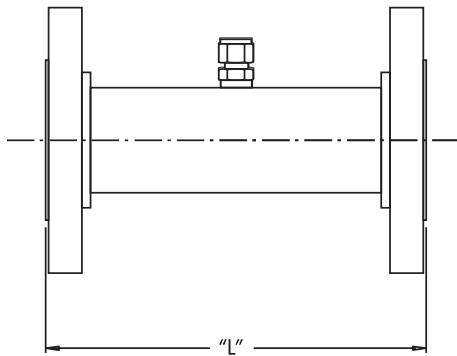

**LENGTH "L" SAME AS NON-FLANGED METER**  
 (See table on page 31. For example, 1"x8" flow body has an 8" length. The length will be the same whether an NPT flow body, or whether flanged. If a flanged flow body, the 8" dimension will be a Face-to-Face dimension.)

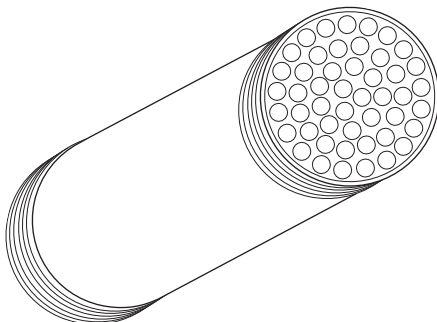
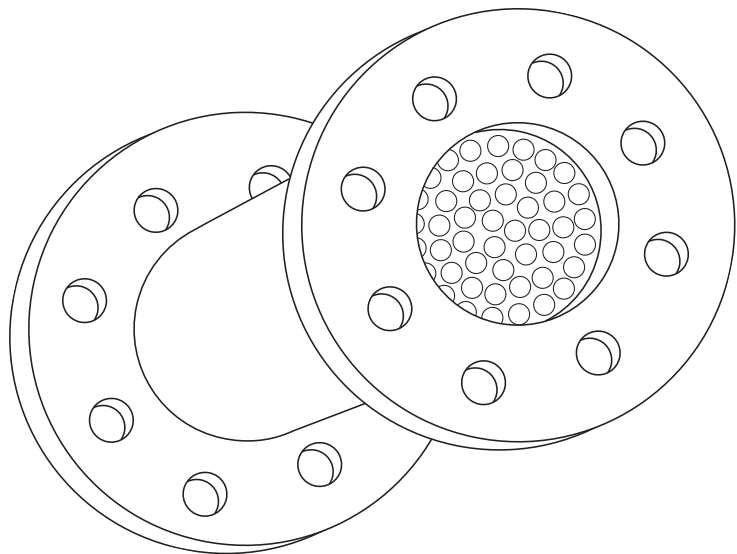

Screens shown with NPT fitting.

<sup>1</sup> Note, Flow conditioning is also available for Insertion Meter applications (see page 13)

## Electrical Wiring

All wiring connections are made in the terminal block compartment of the enclosure. An illustration

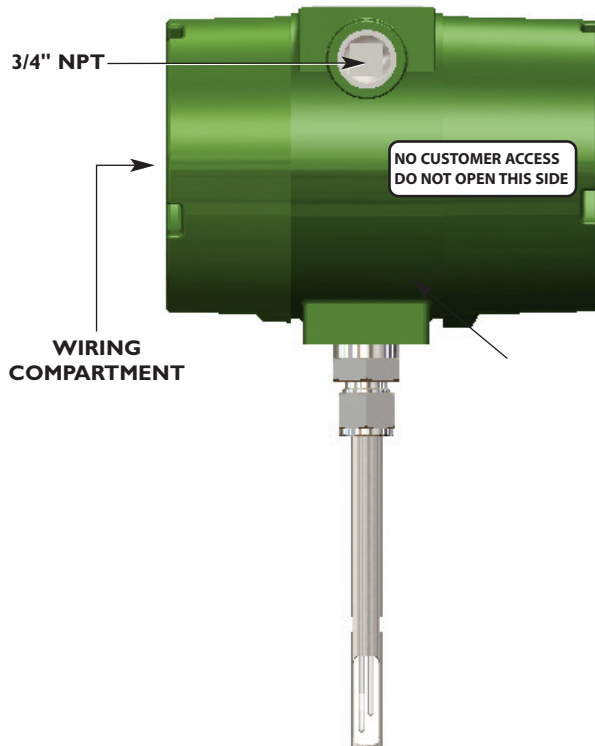

of the wiring connections is found on the inside of the rear cover.

### INSIDE COVER VIEW

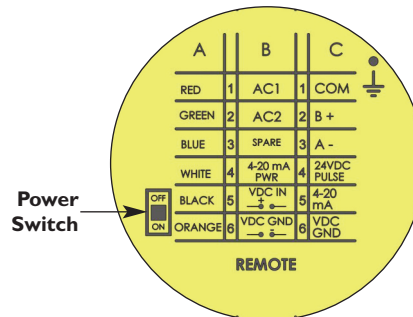
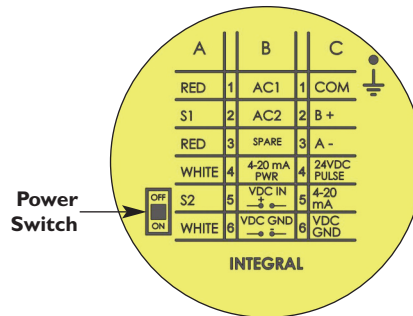

### INPUT POWER

The Sage Rio requires supplemental power in the form of 24 VDC or 115/230 VAC. Power requirements at 24 VDC is 2.4 watts. The AC and DC

ground connections are made at the green grounding screw located adjacent to the terminals.

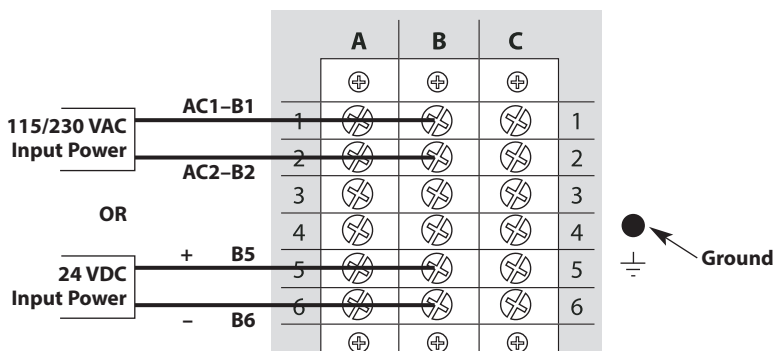

AC POWER		
	115	230
AC1	Line	Phase A
AC2	Neutral	Phase B

## Output Wiring

**NOTE: FOR UNITS WITH HART COMMUNICATION SEE PAGE 62 FOR ELECTRICAL WIRING CONNECTIONS OF THE 4-20 mA SIGNAL AND PULSE OUTPUT.**

Both a 4-20 mA and a pulse output are available. These outputs can be either externally or internally powered. The pulse and 4-20 mA outputs both share

the same power, so both will be internally powered or externally powered.

### 4-20 mA AND PULSE OUTPUT USING SEPARATE EXTERNAL POWER SUPPLIES

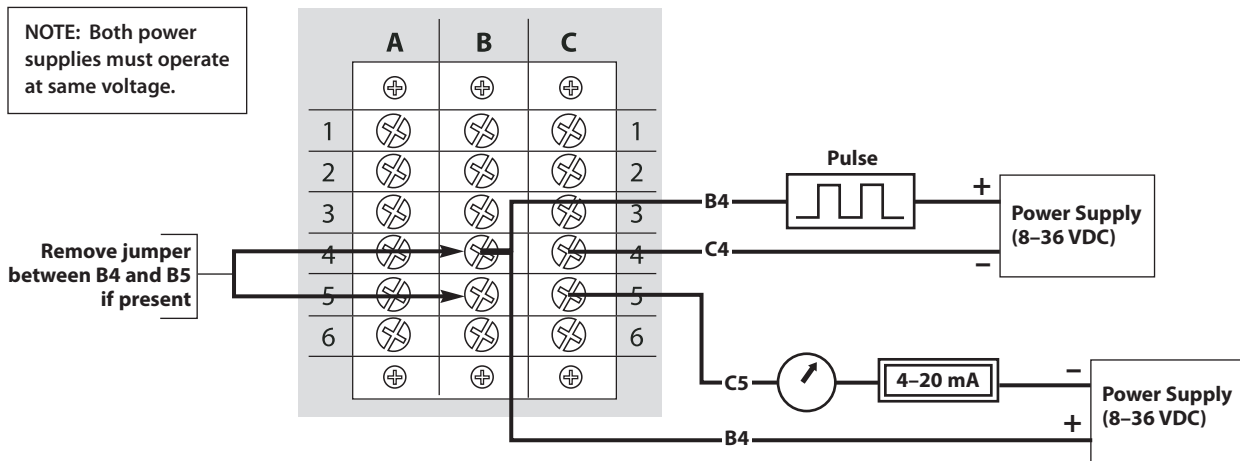

### 4-20 mA AND PULSE USING ONE EXTERNAL POWER SUPPLY

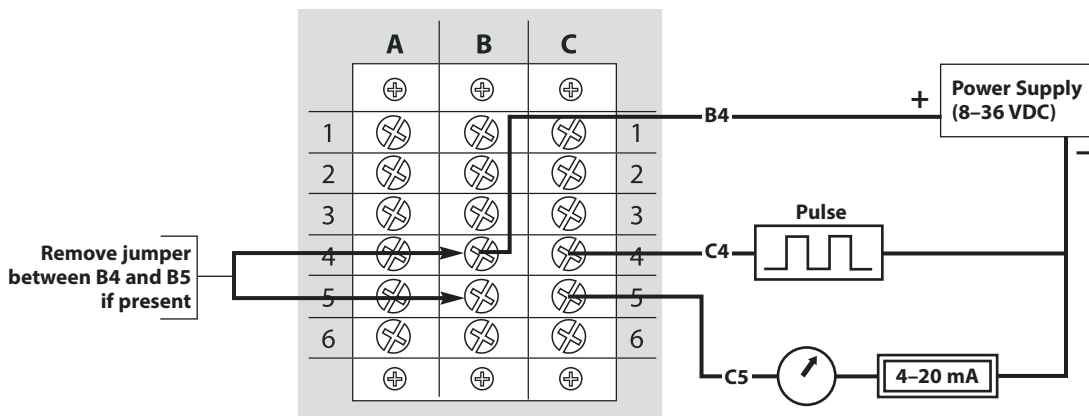

### PULSE OUTPUT

The pulse output is 0–10 Hz. The default pulse width is 250 ms. Externally powered voltage can range between 8 and 36 VDC with load not exceeding 100 mA. Internally powered voltage will be 24 VDC +/- 10%. Minimum voltage is 1 VDC.

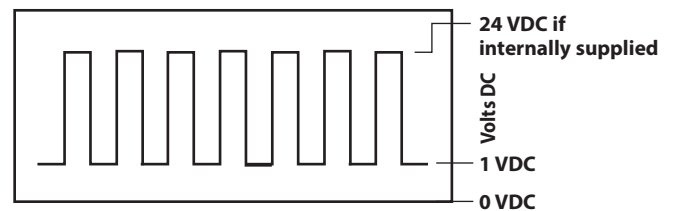

**INTERNALLY POWERED 4–20 mA AND PULSE**

NOTE: If using internally powered 4–20 mA and pulse the output is not isolated.

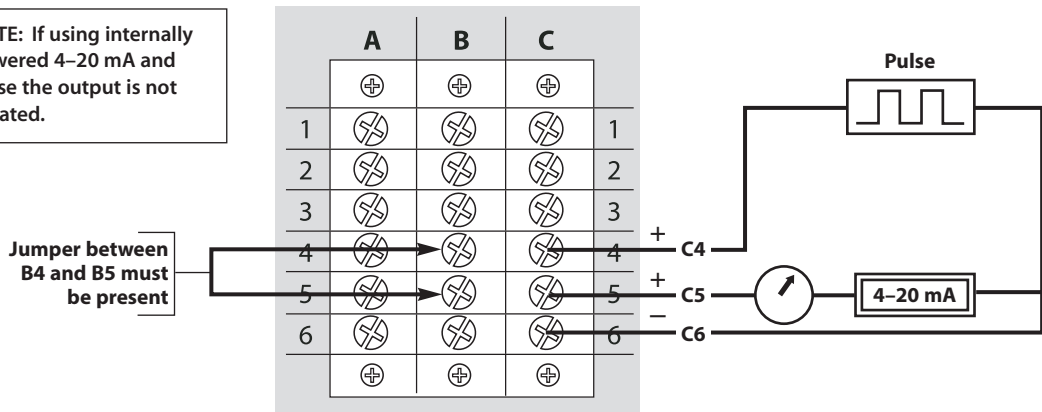

**MODBUS CONNECTIONS**

Modbus RS 485 RTU communications is available on non-HART units.

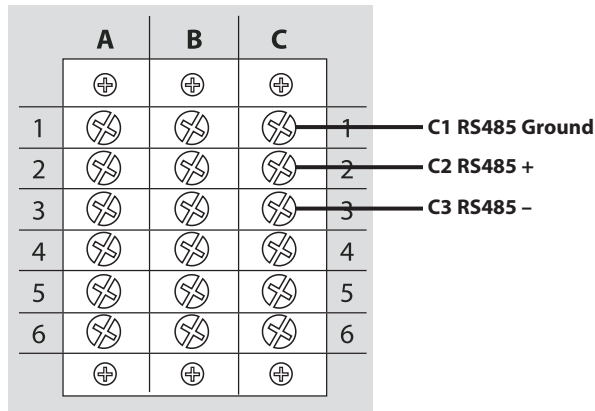

**INTEGRAL ELECTRONICS SENSOR CONNECTIONS**

Wiring between the sensor and the electronics is completed and tested by Sage. These connections are rarely accessed by the user.

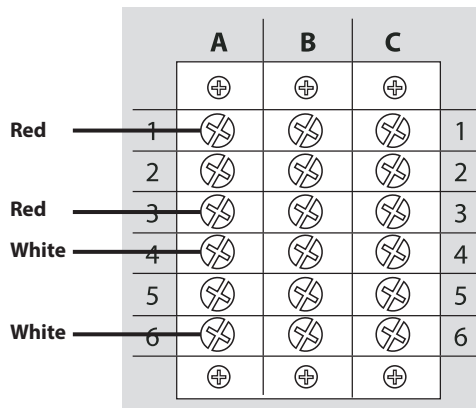

### REMOTE CABLE WIRING

Used to connect the main electronics with remote sensor.

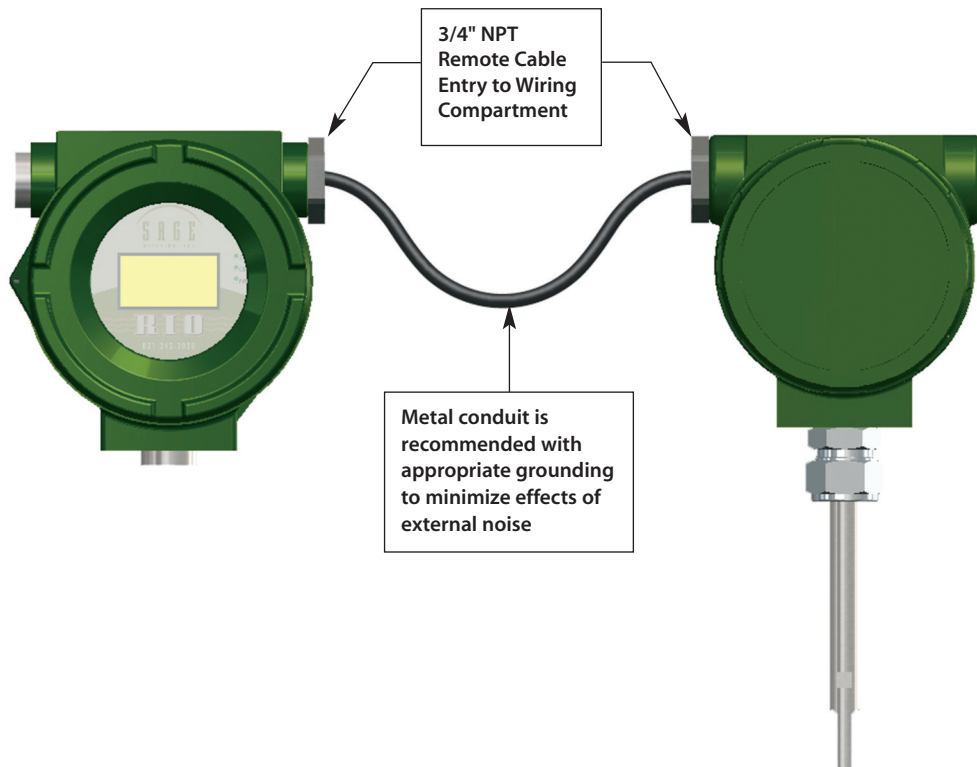
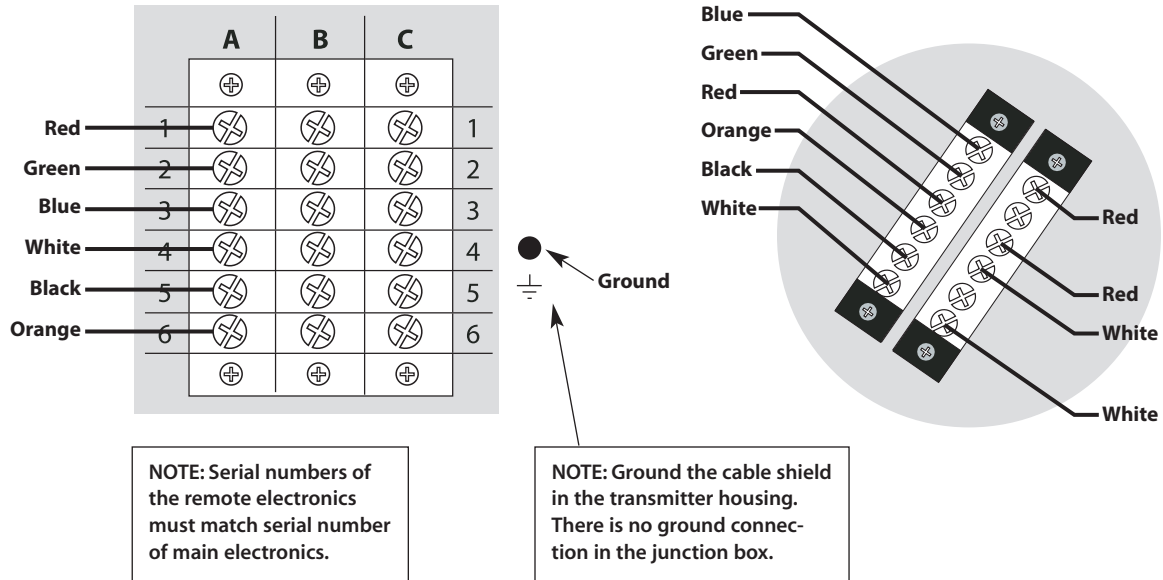



**Section**

**B**

**STYLES AND FEATURES**



## Principle of Operation of the Thermal Mass Flow Meter

Sage Thermal Mass Flow Meters have two sensors constructed of reference grade platinum windings (RTDs). The two RTDs are clad in a protective 316SS or Hastelloy C sheath and are driven by a proprietary sensor drive circuit. One of the sensors is self-heated (flow sensor), and the other sensor (temperature/reference sensor) measures the gas temperature. The pair is referred to as the sensing element, and is either installed in a probe as an Insertion style, or inserted into a pipe section as an In-Line style flow meter.

As gas flows by the flow sensor, the gas molecules carry heat away from the surface, and the sensor cools down as it loses energy. The sensor drive circuit replenishes the lost energy by heating the flow sensor until it is a constant temperature differential above the reference sensor. The electrical power required to maintain a constant temperature differential is directly proportional to the gas mass flow rate and is linearized to be the output signal of the meter.

It is essential that this constant temperature differential be maintained, even if there are wide fluctuations in gas temperature. It is the “job” of the Sage proprietary sensor drive circuit to maintain the differential, whether or not the gas temperature changes, or however quickly molecules cool off the flow sensor. It is also necessary to properly calibrate the device with the actual gas (or close equivalent with certain gases), in the Sage National Institute of Standards certified (NIST) calibration facility. By accomplishing these two critical objectives, the Sage meters provide an extremely repeatable (0.2% of Full Scale) and accurate output directly proportional to the mass flow rate of the gas being measured.

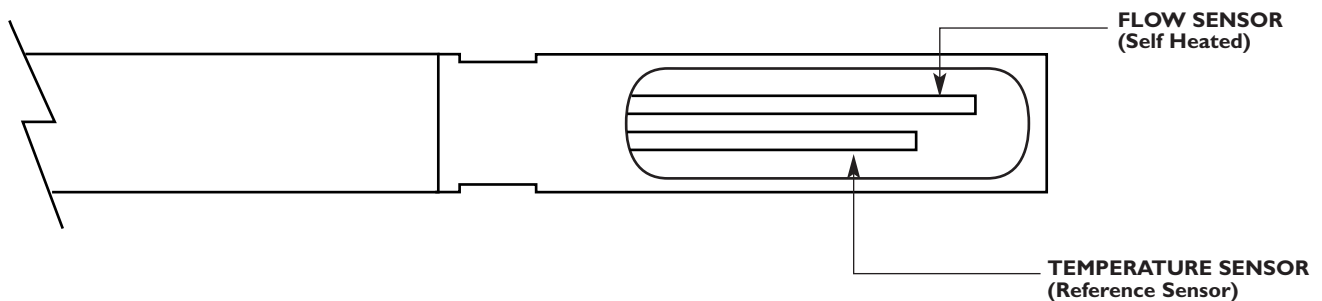

## Features and Benefits

### SAGE RIO THERMAL MASS FLOW METER FOR GASES

The Sage Rio Thermal Mass Flow Meter provides the same levels of performance found in the popular Sage Prime with the added ATEX Zone 1 Flameproof approvals. The Rio features a bright, high contrast, photo-emissive OLED (Organic LED) display of Flow Rate, Total and Temperature in an explosion proof, dual-sided IP66 (NEMA 4X) enclosure. The Flow Rate is also displayed graphically in a horizontal bar graph format. The rear compartment is completely separated from the electronics, and has large, easy-to-access, well marked terminals, for ease of customer wiring. It is powered by 24 VDC (115/230 VAC optional). The power dissipation is under 2.5 watts (e.g. under 100 mA at 24 VDC).

Standard outputs include 4-20 mA with HART communication<sup>1</sup>, pulsed outputs of totalized flow and full Modbus compliant RS485 communication.

Sage Rio is Zone 1 approved:  II 2G Ex d IIB+H2 T6 Gb. T6 Rating is suitable for gases with ignition temperature as low as 185°F (85°C).

### CONTINUOUS DIAGNOSTICS & FIELD CONFIGURABILITY

Rio has continuous diagnostics. The raw calibration milliwatts (mw) is always displayed in the upper left hand corner of the meter's display. At any time, you can check this reading at a "No Flow" (0 SCFM) condition, and compare the reading to the original reported "No Flow" value noted on the last few lines of your meter's Certificate of Conformance or the Flow Meter's data tag. This in-situ diagnostic procedure not only checks the sensor performance and the "Live Zero" calibration point, but it also verifies that the sensor is clean. It essentially provides a means to validate that the meter is operating properly, verifies that there is no shift or drift, and eliminates the need for annual factory calibrations. This simple field diagnostic procedure, in addition, verifies that the sensor is free from contamination, even without inspection.

Although Sage Rio is fully configured upon shipment for the pipe and process conditions requested, if changes are needed, HART or Addresser software is optionally available.

### MAJOR BENEFITS OF THERMAL MASS FLOW METERS

- Direct Mass Flow – No need for separate temperature or pressure transmitters
- High Accuracy and Repeatability – Precision measurement and extraordinary repeatability
- Turndown of 100 to 1 and resolution as much as 1000 to 1
- Low-End Sensitivity – Measures as low as 5 SFPM (e.g., 1 SCFM in a 6" pipe)
- Negligible Pressure Drop – Will not impede the flow or waste energy
- No Moving Parts – Eliminates costly bearing replacements, and prevents undetected accuracy shifts
- Dirt Insensitive – Provides sustained performance
- Low cost-of-ownership
- Ease of installation and convenient mounting hardware

### SPECIFIC BENEFITS OF THE SAGE RIO

- Features In-Situ "Field Zero Calibration Check" of sensor's performance – verifies that the sensor is clean, and assures that there is no drift, or shift in the flow meter
- ATEX Zone 1 Approval with T6 Rating suitable for gases with ignition temperature as low as 185°F (85°C). Also UL, CSA and CE approved
- High contrast photo-emissive OLED display with numerical Flow Rate, Total and Temperature, as well as Graphical Flow Indicator
- Calibration milliwatts (mw) is continuously displayed, providing for ongoing diagnostics
- Proprietary hybrid-digital sensor drive circuit provides enhanced signal stability and temperature compensation
- Modbus<sup>®</sup> compliant RS485 RTU communications (HART<sup>®</sup> optional)<sup>1</sup>
- Isolated 4-20 mA<sup>3</sup> output and pulsed output of Totalized Flow
- Heavy industrial packaging with easy terminal access
- Optional Remote Style with Lead-Length Compensation. Allows remote electronics up to 1000 feet from probe; Explosion Proof Junction Box has no circuitry, just terminals (suitable for harsh environments)
- Low power dissipation, under 2.5 Watts (e.g. under 100 mA at 24 VDC)
- Field reconfigurability via optional Addresser software
- Flow conditioning built into In-Line flow meters (1/2" and up)
- Captive Flow Conditioners for Insertion meter applications, if required

<sup>1</sup> Specify HART in the Flow Meter part number

## Sage Rio Styles and Specifications

SAGE METERING is a manufacturer of high performance Thermal Mass Flow Meters which measure the flow rate and consumption of gases for multiple industrial applications. Frequently used for energy management systems to monitor and improve energy efficiency as well as for regulatory compliance in environmental systems including reporting of Greenhouse Gas Emissions.

TYPICAL APPLICATIONS include measurement and sub-metering of natural gas and compressed air for energy utilization and cost accounting within a facility. Measurement of combustion air flow can be used for improving efficiency in boilers

and furnaces. Environmental reporting of Greenhouse Gases from combustion sources as well as measurement for carbon credits are frequently encountered.

OTHER KEY environmental applications include flare gas flow measurement in the Oil and Gas Industry where thermal technology offers economic advantages over traditional flow measurement technology. To meet the regulatory requirements of periodic re-calibration or calibration verification, Sage Metering has developed a unique in-situ accuracy verification process to ensure the meter is performing within the original NIST traceable gas calibration while the process remains in operation.

### SIX SERIES – INSERTION PROBES

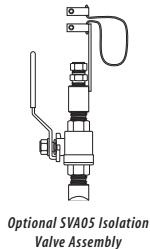

### SIX SERIES – IN-LINE PROBE



1/4" to 4" flow body with flow conditioners 1/2" and above (NPT standard, flanges optional)

(Shown with optional flanged ends)

### GENERAL INFORMATION

#### SENSOR

Two reference grade Platinum RTDs clad in 316SS or Hastelloy C sheath

#### MATERIAL

Wetted metal components: 316SS or Hastelloy C sheath

#### POWER

24VDC Standard (115/230VAC optional)

#### POWER DISSIPATION

<2.5 w (for 24VDC Models)

#### ELECTRONICS

Microprocessor based (Hybrid-Digital)

#### ELECTRONICS ENCLOSURE

Integral mount, Explosion Proof, Class I, Zone 1, Groups B, C, D, Type 4X, IP 66

#### DISPLAY

High contrast photo-emissive OLED graphical display (Flow Rate, Totalizer, Temperature)

**TURNDOWN** 100 to 1

**RESOLUTION** 1000 to 1

**LOW END SENSITIVITY** 5 SFPM

#### FIELD CALIBRATION CHECK

Yes – Digital system allows raw signal validation in milliwatts (In-Situ Calibration Check)

#### COMMUNICATIONS

HART or Modbus® compliant RS485 RTU communications

**FLOW OUTPUT** 4–20 mA<sup>1</sup>

#### FLOW TOTALIZER

24VDC pulse for totalized value

#### TEMPERATURE OUTPUT

Through Modbus® or HART® only

#### FLOW ACCURACY

±0.5% of Full Scale ±1% of reading. (Enhanced accuracy optionally available with limited turn-down)

**FLOW REPEATABILITY** 0.2%

**RESPONSE TIME** 1 second time constant

#### GAS TEMPERATURE RANGE

–40° to 200°F (93°C) Standard. (For higher temperature options, contact Sage)

#### GAS PRESSURE

500 PSIG. (If higher pressure needed, contact Sage)

#### AMBIENT TEMPERATURE

–40° F (–40° C) to 122° F (50° C) for ATEX Rating

#### FIELD RECONFIGURABLE

Optional with HART or Sage Addresser

#### APPROVALS

ATEX Zone 1

Ex II 2 G Ex d IIB+H2 T6 Gb; CSA; UL; CE

**Note:** T6 Rating is suitable for gases with ignition temperatures as low as 185°F (85°C)

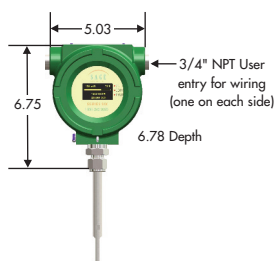

#### STYLE

Insertion Mass Flow Meter

#### PROBE STYLE/LENGTH

1/2" OD Probe Lengths 6" to 36"

#### FLOW CONDITIONING

Captive Flow Conditioners available upon request with meter purchase

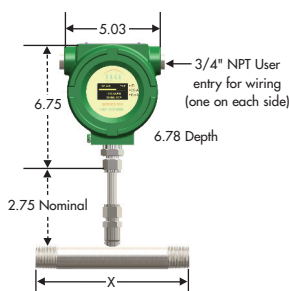

#### STYLE

In-Line Mass Flow Meter

#### FLOW BODY

316SS Schedule 40 Flow Bodies sized from 1/4" x 6" long to 4" x 12" long. Male NPT ends standard. (Flanges and other options available)

#### FLOW CONDITIONING

Flow conditioners are built in to In-Line Style Flow Bodies from 1/2" to 4"

### REMOTE STYLE SRX

Optional Remote Styles available with lead-length compensation (up to 1000 ft). Contact Sage for further information.



See Sage Metering Product Brochure for additional information and product benefits, or visit us at [www.sagemetering.com](http://www.sagemetering.com)

## Sage Rio Organic (OLED) Display<sup>1</sup>

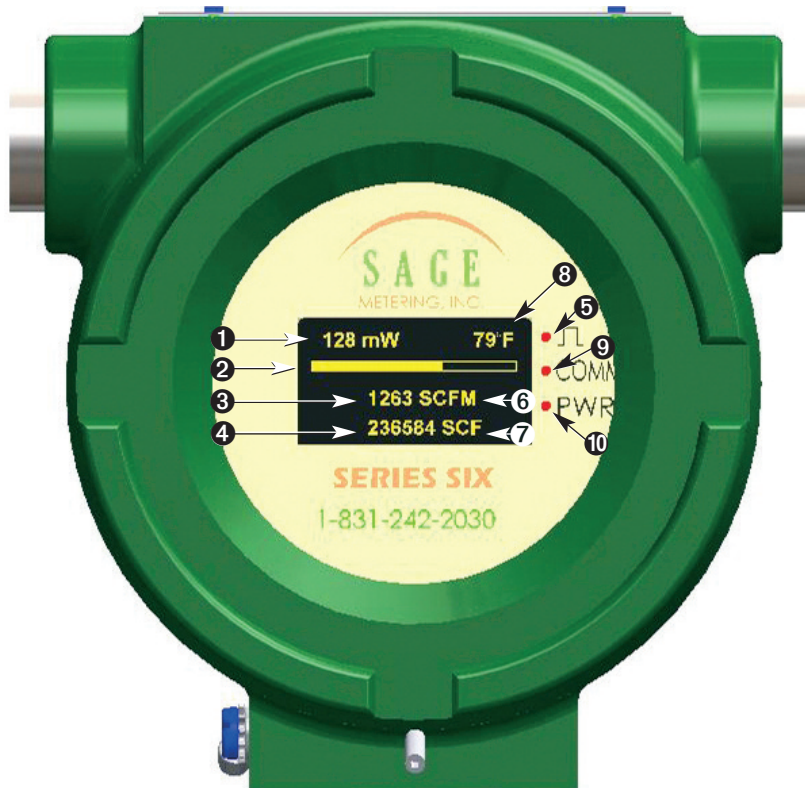

- ❶ Raw Calibration milliwatts (mw) for Diagnostics and Periodic “Zero Flow” Calibration Check
- ❷ Graphical Indication of Percentage of Full Scale Flow Rate
- ❸ Flow Rate
- ❹ Totalized Flow (Consumption)  
(Value is Retained during Power Outage or Power Cycling)
- ❺ Flashes with each pulsed output of consumption
- ❻ Engineering Units of Flow Rate (the last digit can be S(seconds), M(minute), H(hour))
- ❼ Engineering Units of Consumption
- ❽ Temperature
- ❾ Indicates when HART or Modbus is being transmitted
- ❿ Indicates when HART or Modbus is being received

<sup>1</sup> Upon start-up, the Revision No., Serial No., and Modbus ID will display for a few seconds. Also the output configurations symbol is momentarily displayed





## DECLARATION OF CONFORMITY

**Application of Council Directive(s):** European Union/CE Mark per EMC Directive

2004/108/EC

**FCC Part 15**



**II 2 G Ex d IIB+H2 T6 Gb**

### Standards to which Conformity is Declared:

Emissions: EN 61326-1:2006

EN 55011:2009, FCC Part 15 Subpart B:2011, VCCI V-3/2011.04, BSMI CNS 13438:2006,

EN 61000-3-2:2006/A2:2009, EN 61000-3-3:2008

Immunity: EN 61326-1:2006

EN 61000-4-2:2009, EN 61000-4-3:2006/A2:2010,

EN 61000-4-4:2004+A1:2010, EN 61000-4-5:2006,

EN 61000-4-6:2007, EN 61000-4-8:2010, EN 61000-4-11:2004

### ATEX Standards to which Conformity is Declared:

EN 60079-0:2009

EN 60079-1:2007

**Declarer's Name:** Sage Metering, Inc.

**Declarer's Address:** 8 Harris Ct. Bldg D1, Monterey, CA 93940

**Type of Equipment:** Sage RIO SIX & Sage RIO SRX

*I the undersigned, hereby declare that the equipment specified above conforms to the above Directive(s) and Standard(s).*

A handwritten signature in blue ink, appearing to read "GAR".

(Signature)

5/3/2012

Gary Russell

(Printed name)

Production Engineer

## SIX Series Integral Style Mass Flow Meters

### IN-LINE STYLE<sup>1,3</sup>

150#, 300#, or 600# flanged ends are optionally available.  
(150# flanges recommended on 3" and 4" Flow Bodies)

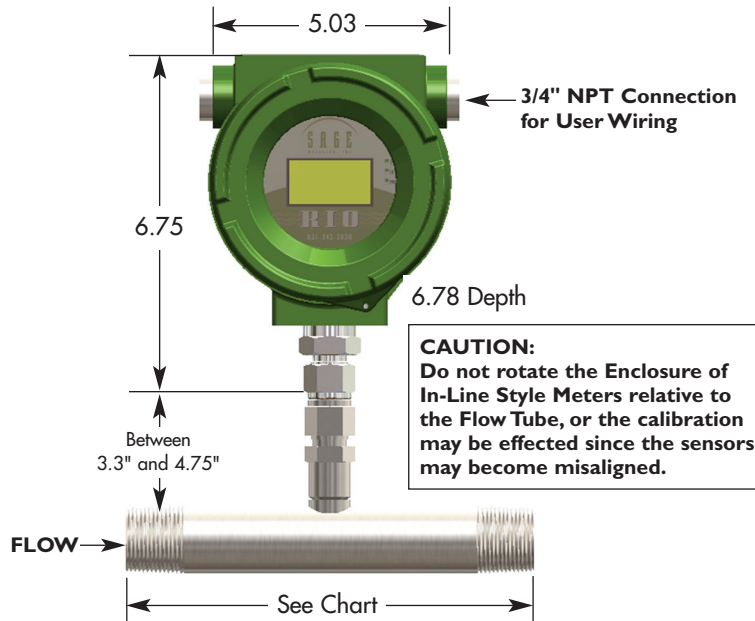

### IN-LINE METER DIMENSIONS

Pipe Size x Flow Body Length (B) <sup>3</sup>
1/4" x 6"
3/8" x 6"
1/2" x 7"
3/4" x 7"
1" x 8"
1-1/4" x 10"
1-1/2" x 12"
2" x 12"
2-1/2" x 12"
3" x 12"
4" x 12"

Depth: DC Enclosure depth is 4.35"  
AC Enclosure depth is 5.35"

### INSERTION STYLE<sup>2</sup>

150#, 300#, or 600# flanged mounting is optionally available. Available probe lengths are 6", 12", 15", 18", 24", 30" or 36". Standard probe is 1/2" diameter.

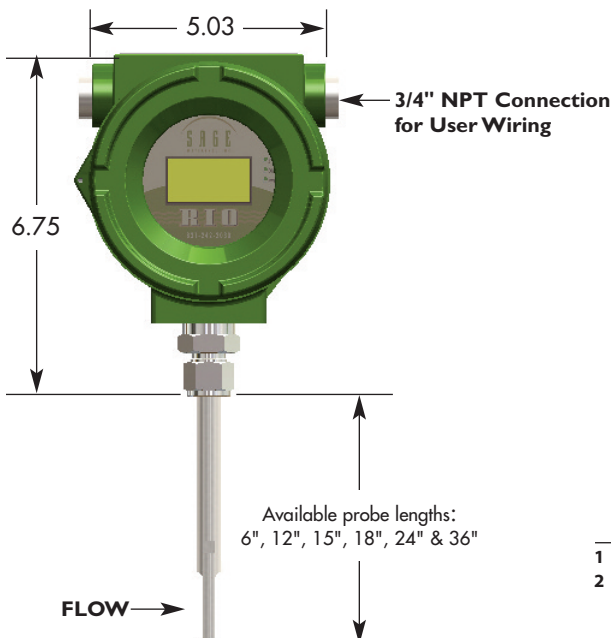

<sup>1</sup> NPT Fittings standard

<sup>2</sup> Flanged Mounting available for high pressure operation

## SRX Series Remote Style Mass Flow Meters

### IN-LINE STYLE<sup>1,3</sup>

150#, 300#, or 600# flanged ends are optionally available. (150# flange recommended on 3" and 4" Flow Bodies)

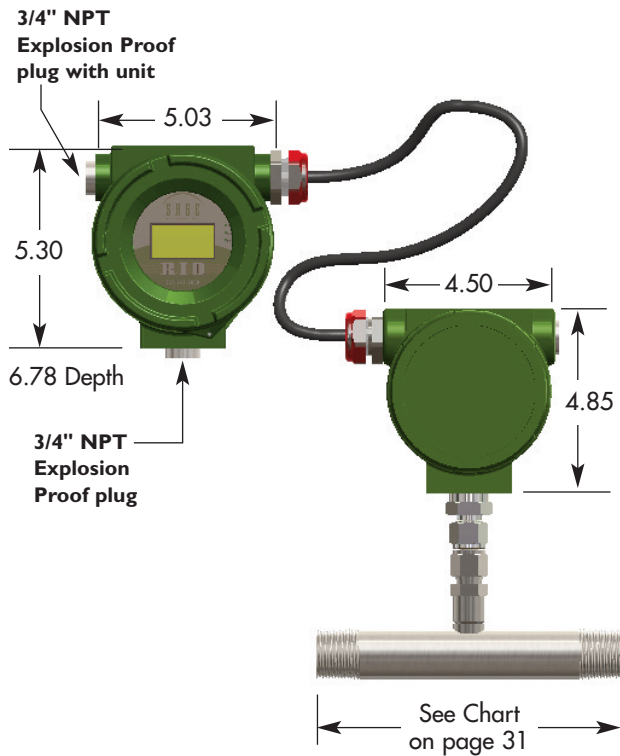

**CAUTION:**

Do not rotate the Junction Box of In-Line Style Meters relative to the Flow Tube, or the calibration may be effected since the sensors may become misaligned.

### INSERTION STYLE<sup>2</sup>

150#, 300#, or 600# flanged mounting is optionally available. Available probe lengths (C) are 6", 12", 15", 18", 24", 30" or 36".

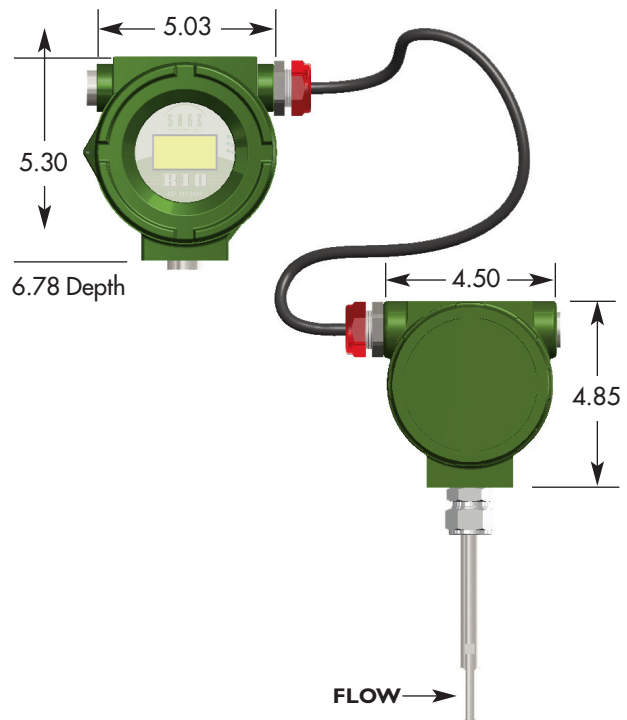

<sup>1</sup> NPT Fittings standard

<sup>2</sup> Flanged Mounting available for high pressure operation

<sup>3</sup> See Chart on page 31.

## Sage Rio Remote Bracket Layout

### MOUNTING OPTIONS

1. Overhead with U-bolts (customer supplied) across pipe on each leg
2. Vertically, as shown
3. Horizontally

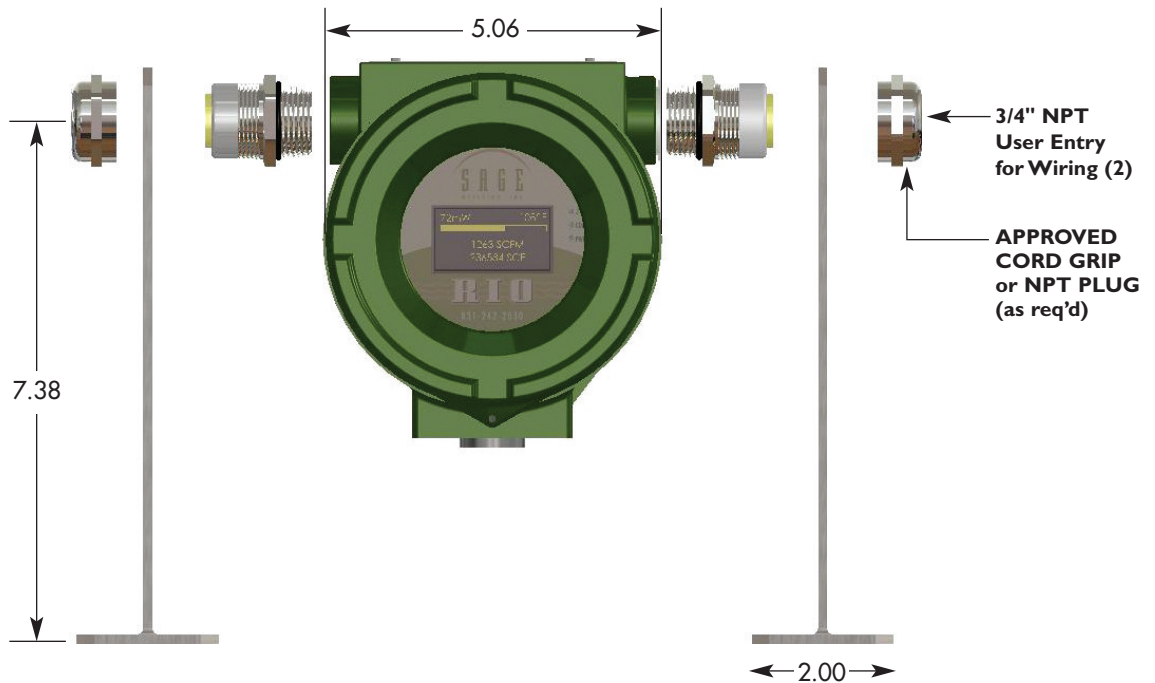
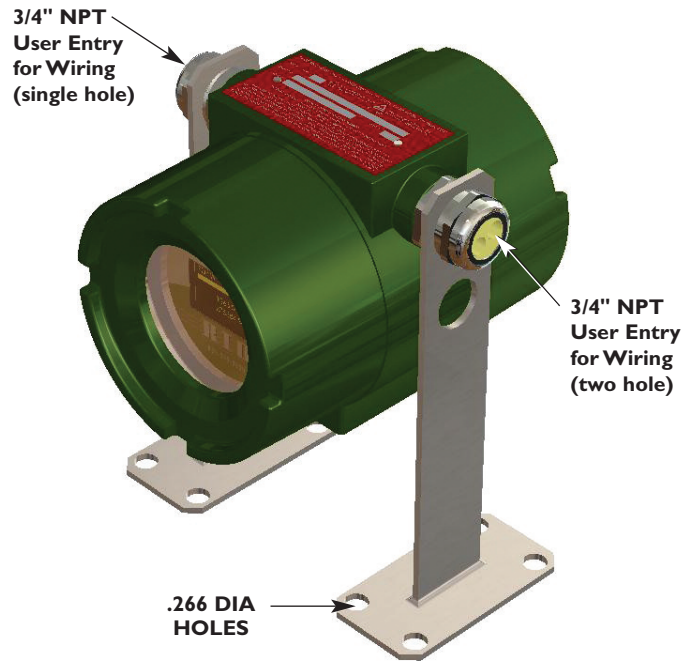

## Mounting Hardware<sup>3</sup>

### SVA05 SERIES ISOLATION VALVE ASSEMBLY FOR INSERTION METERS<sup>4</sup>

(for Low Pressure SVA05 see page 35)

Used for pressures to 250 psig<sup>1</sup> (shown for use with 1/2" diameter insertion meters). 150# or 300# flanged mounting is optionally available. Available sizes are 1/2" x 3/4" NPT (SVA05 shown), and 3/4" x 1" NPT for use with 3/4" diameter insertion meters (SVA07).

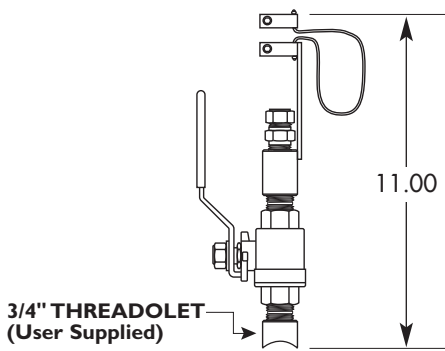

**NOTE:** User needs to weld a 3/4" female threadolet (of appropriate radius) (of appropriate radius) to mate with existing pipe after a 3/4" hole has been drilled in pipe. The 3/4" Male Coupling of the Sage Isolation Valve Assembly will thread into the user's 3/4" threadolet.

PROBE LENGTH (with sensor)	SAFETY CHAIN LENGTH <sup>5</sup>
12"	8.25"
15"	11.25"
18"	14.25"
24"	20.25"

### SVA05 SERIES ISOLATION VALVE ASSEMBLY DETAIL<sup>5,6</sup>

Cut away view of probe inserted through isolation ball valve assembly.

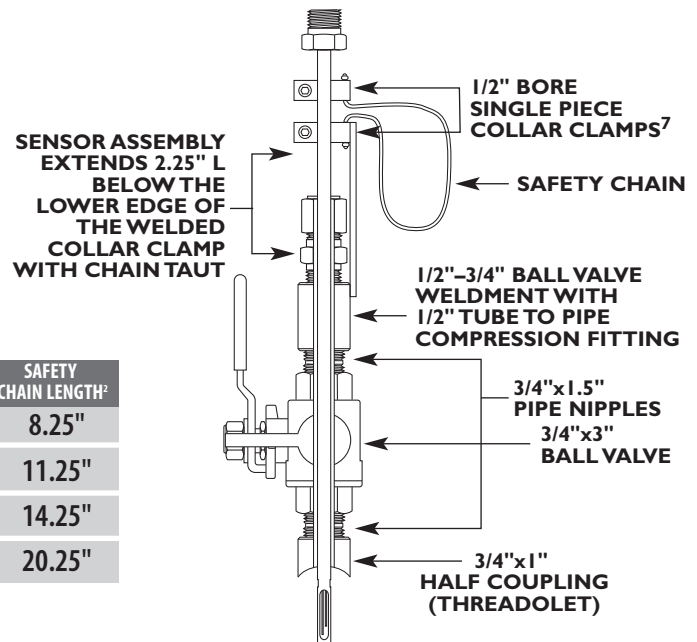

### STCF SERIES TEFLON FERRULE COMPRESSION FITTING

1/2" tube x 1/2" pipe fitting (shown, not to scale), is used for low pressure insertion applications to 125 psig (Stainless Steel Ferrule optional for higher pressure applications – up to 225 psig).

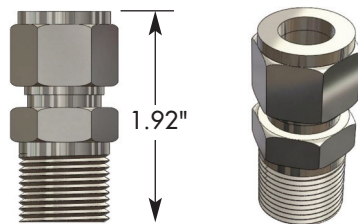

### MOUNTING PLATE FOR THIN WALLED DUCTS (INCLUDES STCF05 COMPRESSION FITTING)

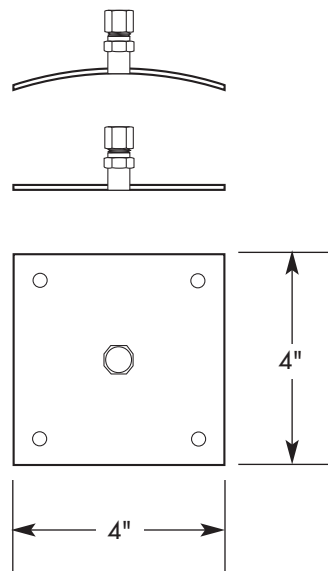

<sup>1</sup> At 650 psig, force exerted on 1/2" diameter probe is 50 lbs.  
<sup>2</sup> Safety chain is designed to prevent probe from accidentally escaping from assembly during removal from pressurized pipe  
<sup>3</sup> Insertion meters can have optional flanged mounting (generally used for high pressure or very hot gases). This adaptation is not shown. Consult factory for details.  
<sup>4</sup> Maximum gas temperature, 200F, unless high temperature models ordered.  
<sup>5</sup> Hot Tapping is feasible by removing Weldment (upper portion of assembly temporarily removed)  
<sup>6</sup> See page 42. SVA05 can be utilized for Sensor Functionality and Zero Self Check.  
<sup>7</sup> The Allen wrench for SVA05 is 9/64 (it is 3/16 for SVA07).

## SVA05LP Low Pressure Isolation Valve Assembly

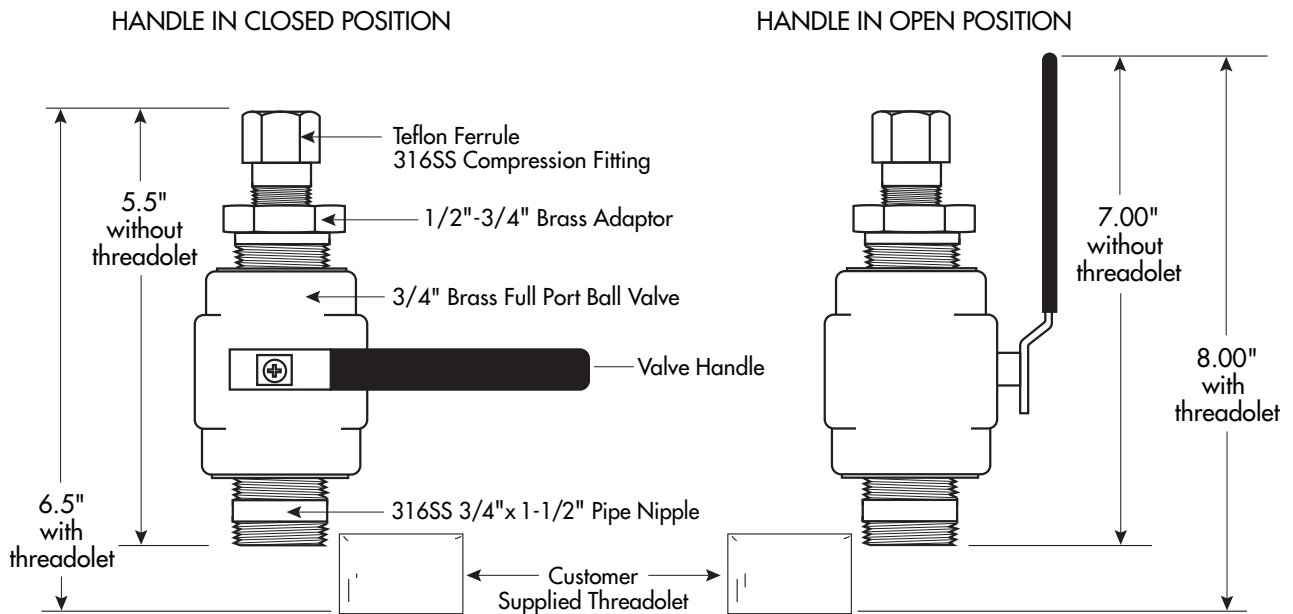

### NOTES AND CAUTIONS

- Suitable for low pressure Air or Natural Gas applications (maximum 50 PSIG)
- Assumes 1/2" Insertion Probe inserted to center of a Pipe (see Sage Probe Insertion Guidelines)
- Teflon Ferrule permits ease of Probe insertion or removal
- Exercise caution when loosening Ferrule nut during insertion and removal of Probe, since this model has no Safety Chain
- Note, maximum upward force is 20% of pipe pressure (i.e., 10 Lbs with 50 PSIG)
- The Assembly will be shipped with a plastic sleeve that protects the 3/4" pipe nipple
- It is the Customer's responsibility to weld a Female Threadolet with correct diameter to pipe

### Flanged Ends for In-Line Meter (OPTIONAL)

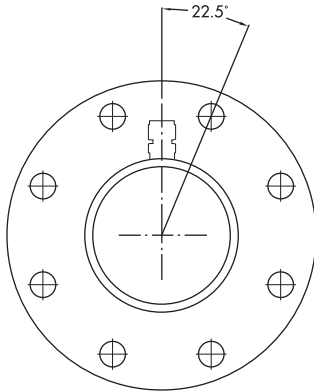

Flanges for 3/2" pipe sizes and up, have 8 bolt holes

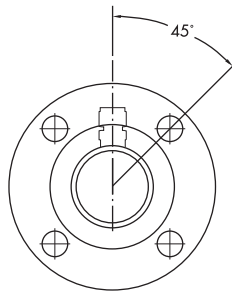

Flanges for 3" pipe sizes and smaller have 4 bolt holes

### Flanged Mounting for Insertion Meter (OPTIONAL)

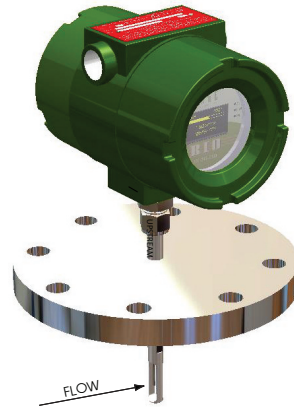

# Section

**C**

**DIAGNOSTICS**



## Common Diagnostics

**SYMPTOM:** Display failure, or pixels extremely dim.

**CORRECTIVE ACTION:** Contact Factory. Certain types of failures are under long term warranty. Please note that the 4-20 ma will still function normally.

**SYMPTOM:** Erratic Readings.

**POSSIBLE CAUSES:** If a large Motor or Generator or Variable Frequency Drive (VFD) is nearby the enclosure, it may be inducing sufficient analog noise into the circuitry to temporarily corrupt the data.

**SUGGESTED CORRECTIVE ACTION:**

- a) If a Power-Restart temporarily solves the problem, than it is likely that the source of the noise was the problem.
- b) To prevent subsequent problems, if a Remote Style Meter, move the enclosure as far away as possible from the source (the Motor or VFD).
- c) If an Integral Style Meter, mount the meter in a different location (further from the source) or move the source further from the meter.

**SYMPTOM:** Erratic Readings on a Remote Meter.

**POSSIBLE CAUSE:** In some cases, analog noise is induced into the Remote cable causing erratic, or climbing readings.

**SUGGESTED CORRECTIVE ACTION:**

- a) Be sure the remote cable is installed in metal conduit and grounded on the transmitter end only.
- b) Also, avoid coiled cable, especially if not in metal conduit.
- c) Also, if extra cable exists, move the extra cable as far away as possible from any source of analog noise, such as large motors or VFDs.

**SYMPTOM:** Meter reading zero continuously, or Full Scale continuously, or temperature reading is abnormally low (hundreds of degrees below zero).

**POSSIBLE CAUSES/SUGGESTED CORRECTIVE ACTION:**

- a) It is likely that a wire is loose. But in rare cases, a sensor could fail (i.e., if a standard sensor, HT01 or HT02 sensor exceeds a process temperature of 450°F.)
- b) Check for continuity to be sure the wiring is making good contact at the terminals of the Junction Box.

c) Also, to verify that the electronics and the sensor serial number are the same, note the following: The sensor's serial number will come up upon power up, right after Initializing on the Display. If the serial number doesn't agree with the Junction Box labels, that would affect calibration (in other words, sensors and electronics are a matched pair—mixing them up will cause false readings). Also metal Serial Number Tags are fastened to both the electronics and the Junction Box. They must have identical Serial numbers.

d) To check if a sensor has failed on a remote style meter, it is easy to use the Junction Box to do so. You must Power Down (shut off power), but you do not need to remove the probe from the pipe. Refer to page 21.

e) An Ohm Meter is required to check across the sensor leads of the Flow Sensor. Look at the drawing of the Junction Box. Disconnect the red wires on the Factory Side to isolate and measure the resistance. If the reading is infinity or a short, it means that sensor has failed.

f) Now check the Temperature Sensor. Disconnect the white wires on the Factory Side to isolate and measure the resistance. If you have infinity or a short, it means that sensor is burned out. **Note:** *Normally the sensors will read approximately 110 ohms at 70° F. At higher temperatures they should read a higher resistance, but both sensors should have a similar value.*

g) On integral style meters (SIX), there is no Junction Box. In that case, refer to the Rio Integral Terminals on page 20 and check the sensor wires. Remove the appropriate wires first (red pair for flow, then white pair for temperature). Measure their resistance. If reading infinity or short, it means that sensor has failed.

**SYMPTOM:** Meter Railing (Pegging) or Reading High

**POSSIBLE CAUSES/SUGGESTED CORRECTIVE ACTION:**

- a) Insufficient straight run (i.e. flow profile is disturbed, causing errors).
- b) Possible jet effect if upstream pipe is smaller than meter flow body or if valve is too close upstream to meter.
- c) Not following Probe Insertion Guideline.

- d) If sensor is inserted in reverse (“Upstream” mark is facing downstream) Meter may over-report (or under-report) by as much as 30%.
- e) If sensor is not aligned properly, with “Upstream” mark facing upstream, a rotation greater than  $\pm 5$  degrees may cause change in reading (greater than  $\pm 5$  degrees and less than  $\pm 20$  degrees causes meter to over-report; a greater rotation actually blocks the sensor, and causes meter to under-report).
- f) A downstream valve too close to the meter (flow may be reflecting back).
- g) Possibly caused by water droplets condensing out of gas stream (which generally causes output to spike; but if droplets are near continuous, output may rail).
- h) Meter is miswired, especially in Remote Style application.
- i) Possibly caused by water droplets condensing on inside of pipe wall, which roll down or hit sensor causing output to spike; but if droplets are near continuous, output may rail. **Note:** *Recommend installation 45° from vertical (see drawing on page 72).*
- j) Possibly caused by water droplets condensing out of gas stream and filling the cavity containing the sensing elements (usually due to probes mounted below horizontal in saturated pipes).
- k) Sensor may be contaminated. Remove probe, wipe off or clean with a solvent. Reinsert.
- l) Using a different gas or gas mix than the meter was specified and calibrated for.
- m) If a Remote Style Meter (SRX), be sure Serial Numbers of Junction Box and Remote Electronics are identical (if not, errors in calibration are inevitable). To confirm, verify that Junction Box Serial Number Tag has identical Serial Numbers to Tag on Remote Enclosure.
- n) Meter may appear to be reading high if user is comparing Sage flow meter readings (SCFM) to an uncorrected volumetric device (ACFM). For example, at constant volume, a decrease in gas temperature will increase the mass flow (SCFM). That is completely normal.

**SYMPTOM:** Reading Low

**POSSIBLE CAUSES:**

- a) Insufficient straight run (i.e. flow profile is disturbed, causing errors).
- b) Poor flow profile Upstream (insufficient upstream straight run).
- c) Not following Probe Insertion Guideline.
- d) If sensor is inserted in reverse (“Upstream” mark is facing downstream) Meter may over-report (or under-report) by as much as 30%.
- e) If sensor is not aligned properly, with “Upstream” mark facing upstream, a rotation greater than  $\pm 5$  degrees may cause change in reading (greater than  $\pm 5$  degrees and less than  $\pm 20$  degrees causes meter to over-report; a greater rotation actually blocks the sensor, and causes meter to under-report).
- f) Sensor may be contaminated. Remove probe, wipe off or clean with a solvent. Reinsert.
- g) Using a different gas or gas mix than the meter was specified and calibrated for.
- h) If a Remote Style Meter (SRX), be sure Serial Numbers of Junction Box and Remote Electronics are identical (if not, errors in calibration are inevitable). To confirm, verify that Junction Box Serial Number Tag has identical Serial Numbers to Tag on Remote Enclosure.
- i) Meter may appear to be reading low if user is comparing Sage flow meter readings (SCFM) to an uncorrected volumetric device (ACFM). For example, at constant volume, an increase in gas temperature will lower the mass flow (SCFM). That is completely normal.
- j) On most models, the Totalizer will not start counting for 10 seconds after power up so any flow data will not be accumulated during this time.
- k) Insufficient power supply—most products require minimum 100 mA.
- l) Excessive load on the 4-20 mA. (To check if problem is due to 4-20 mA output device, temporarily remove device, and observe if display reads as expected).

**SYMPTOM:** Totalizer can take up to 10 seconds to update its reading when flow meter is first powered up, or a channel is changed.

**CORRECTIVE ACTION:** None. This slight delay is completely normal.

**SYMPTOM:** Display does not have power

**POSSIBLE CAUSE:** Mis-wiring

**SYMPTOM:** 4-20 mA output not tracking the flow rate display

**POSSIBLE CAUSE:**

- a) In normal operation (Self Powered) B4 and B5 must be jumpered to supply power to loop. See page 20 or page 62 for Rio units with HART.
- b) In Externally Powered mode, the jumper must be removed. Verify that 9 to 27 Volts DC is supplied to externally power the loop as per page 20 or page 62 for Rio units with HART.

**SYMPTOM:** 4–20 mA output always at 4 mA. Unit has HART communications.

**POSSIBLE CAUSE:** Poll address is not set to 0.

## In-Situ Calibration Check

### RECOMMENDED ON A QUARTERLY BASIS FOR EPA 40 CFR 98 PERIODIC CALIBRATION VERIFICATION, CAR<sup>1</sup> PROTOCOLS, AND CDM<sup>2</sup> PROTOCOLS

Sage RIO has continuous diagnostics. The raw calibration milliwatts (mw) is always displayed in the upper left hand corner of the meter's display allowing the user to conduct an "in-situ" calibration. At any time, you can check this reading at a "no flow" condition and compare the reading to the original reported "zero flow" value noted on the last few lines of your meter's Certificate of Conformance or the flow meter's data tag. This diagnostic procedure not only checks the sensor performance and the "live zero" calibration point, but it verifies that the sensor is clean. It essentially provides a means to validate that the meter is operating properly, verifies that there is no shift or drift, and eliminates the need for annual factory calibrations. This simple field diagnostic procedure also verifies that the sensor is free from contamination, even without inspection.

#### 1. Verify that meter has no gas flow<sup>3</sup>

Close appropriate valves in the process to have a "no flow" condition so you can check the "live zero" mw output of the actual gas (it should be checked at the same pressure as noted on Certificate of Conformance).

If it is not possible to close valves in the process (e.g. natural gas supply must be kept flowing), a user with a Sage SVA05 or SVA07 Isolation Valve Assembly can check "zero" of the actual gas and pressure without shutting off the gas supply. Refer to SVA SERIES ISOLATION VALVE ASSEMBLY DETAILS ON PAGE 34.

- Loosen lower Collar Clamp completely<sup>4</sup>
- Slightly loosen compression fitting until Probe can be lifted
- Lift Probe until Safety Chain is taut
- Tighten compression fitting
- Close Valve
- Check zero mw as per "2" below

Optionally, do an ambient air check by removing probe and covering up sensor by capping the sensor with a plastic bag, empty plastic water bottle or other means of preventing flow (see 8).

- Observe the raw mw on the top of the meter's display. After one to three minutes of "no flow" stabilization, check the observed reading against the flow meter's data tag or last line(s) of your Meter's Certificate of Conformance.
- A value within 5 milliwatts of the original Factory value (assuming the same gas is checked at same pressure) indicates that meter is still in calibration.
- A value greater than 5 mw, but less than or equal to 10 mw, also indicates that the meter is still in calibration, but this reading may have been influenced by one or more of the following factors: gas

composition, pressure, dirt, non-zero conditions, and sensor orientation. Any of these factors can have an effect on mWo. It is a very sensitive data point; that is why it is such a good check.

- Note, if all of the above factors were remedied, it would be expected that the mW zero would report less than or equal to 5 milliwatts.
- Note, in some cases, contamination of the sensor is the only cause of the additional heat transfer during the "no flow" test. Remove probe, and clean the sensor (use an appropriate non-corrosive solvent to remove build up). A soft brush can be used to gently clean the sensing surface, using caution to avoid damaging the sensor elements (the RTD's).
- In summary, if a technician in the field were able to simulate Sage calibration conditions, he too would find that the mWo would be within one mW or very close to that. Since this is not always possible, we are finding that after considering all of the field variables, a mWo in the field that is within 10 mW is an acceptable value (see 9). This would allow for a check to be done in the pipe under application conditions.
- Note, if desired, a second check can be conducted as well but using ambient air: This validation method requires that the sensor be removed from the pipe and inserted in a container such as an empty plastic water bottle.
- For CAR<sup>1</sup> compliance Sage recommends a quarterly In-Situ Calibration Check for the following Protocols: *U.S. Landfill Protocol, Version 4.0, Par. 6.2*  
*Mexico Landfill Protocol, Version 1.1, Par. 6.2*  
*U.S. Livestock Protocol, Version 3.0, Par. 6.2*  
*U.S. Livestock Protocol, Version 4.0, Par. 6.3*  
*Mexico Livestock Protocol, Version 2.0, Par. 6.2*  
As per the protocols, the maximum allowable drift is 5%.
- Percent drift can be determined by dividing the mW drift by the mW span. The mW span can be found on the Calibration Data sheet supplied with the meter.

<sup>1</sup> CAR is the Climate Action Reserve. The Climate Action Reserve is a national offsets program working to ensure integrity, transparency and financial value in the U.S. carbon market. It does this by establishing regulatory-quality standards for the development, quantification and verification of greenhouse gas (GHG) emissions reduction projects in North America. The Climate Action Reserve operates alongside its sister program, the California Climate Action Registry (California Registry), which was created by the State of California in 2001 to address climate change through voluntary calculation and public reporting of emissions.

<sup>2</sup> CDM Methodologies, ACM 0001, "Methodological tool to determine the mass flow of a greenhouse gas in gaseous stream" (EB61 Report, Annex 11, Page 1).

<sup>3</sup> Sage "zeros" the meter in a horizontal pipe. If you have a vertical pipe, mW will be slightly lower at zero (also see note 4).

<sup>4</sup> The allen wrench to loosen collar clamp is 3/4" on the SVA05 (it is 3/8" on the SVA07).

# Section

**D**

**WARRANTIES AND  
SERVICE WORK**



## Warranties and Service Work

### LIMITED WARRANTY

Sage Metering's products are warranted against faulty materials or workmanship for one year from the date of shipment from the factory. Sage's obligation is limited to repair, or at its sole option, replacement of products and components which, upon verification by Sage at our factory in Monterey, California, prove to be defective. Sage shall not be liable for installation charges, for expenses of Buyer for repairs or replacement, for damages from delay or loss of use, or other indirect or consequential damages of any kind. This warranty is extended only to Sage products properly used and properly installed for the particular application for which intended and quoted; and does not cover water damage due to improper use of cord grips or removal of protective caps; and does not cover Sage products which have been altered without Sage authorization or which have been subjected to unusual physical or electrical stress. Sage makes no other warranty, express or implied, and assumes no liability that goods sold to any purchaser are fit for any particular purpose. Transportation charges for materials shipped to the factory for warranty repair are to be paid by the shipper. Sage will return items repaired or replaced under warranty, prepaid. NOTE: No items will be returned for warranty repair without prior written authorization from Sage Metering, Inc. Sage does not warranty damage due to corrosion.

### GENERAL TERMS AND CONDITIONS

Detailed General Terms and Conditions can be found on the Sage website ([www.sagemetering.com](http://www.sagemetering.com)) on a link "General Terms" on the Footer of any page on the website.

### CANCELLATION / RETURN POLICY

**Cancellation or Return:** After issuance of a purchase order (by phone, mail, e-mail or fax) or a credit card order (by phone, mail, e-mail or fax), there will be a cancellation fee for any cancelled order. Cancellations must be in writing (by mail, e-mail or fax):

- 1) If credit card order or non-credit card order is cancelled within 7 days of issuance of purchase order or date order was placed (which ever is earlier), there will be a 10% cancellation fee.
- 2) If credit card order or non-credit card order is cancelled after 7 days, but prior to shipment, there will be a 20% cancellation fee. (If order is cancelled due to late delivery, the cancellation fee will be waived. Late delivery is defined as shipping a meter 7 days or later than the delivery date acknowledged by Sage Metering at time of placing order).
- 3) If a credit card customer decides to return the equipment after shipment for credit, credit will not be issued if equipment is damaged or if equipment is returned after four (4) months of shipment. If equipment is not damaged, then equipment can be returned after issuance of a Return Meter Authorization (RMA) by Sage. **Returned package must be insured by customer and must reference proper RMA# on outside of package**, or package may be rejected (i.e., package will be returned unopened). Credit Card customers will be charged a 30% re-stocking fee (70% balance will be credited back). Customer is responsible for return shipping charges and any damage if improperly packaged.

*continued on next page*

- 4) If a non-credit card customer decides to return the equipment after shipment for credit, credit will not be issued if equipment is damaged or if equipment is returned after 1 month of shipment, unless authorized by a representative at Sage Metering, Inc. The Sage representative will issue a Return Material Authorization (RMA) at that time and will advise of the restocking fee. **Returned package must be insured by customer and must reference proper RMA# on outside of package**, or package may be rejected (i.e., package will be returned unopened). Customer is responsible for return shipping charges and any damage if improperly packaged.

## RETURNING YOUR SAGE METER

A Return Material Authorization Number (RMA#) must be obtained prior to returning any equipment to Sage Metering for any reason. RMA#s may be obtained by calling Sage Metering at 831-242-2030 between 7:00 am and 4:00 pm Monday through Friday, or email: [service@sagemetering.com](mailto:service@sagemetering.com).

A Sage RMA Form (see page 50) must be filled out and included with the meter being returned to Sage Metering. RMA Form is also accessible by clicking the “Contact” tab of the Sage website ([www.sagemetering.com](http://www.sagemetering.com)).

**Take special care when packaging your meter for return to the factory. The sensor in particular may easily be damaged if not prevented from shifting around within the package and if the sensor itself is not covered to keep it from contacting other package contents. Any damage resulting from improper packaging is the responsibility of the shipper.**

Once an evaluation is completed and a quote has been issued, you can choose to proceed with the work or have the unit returned with only the evaluation fee in the amount of \$175 plus freight billed.

In accordance with the “Right to Know Act” and applicable US Department of Transportation (DOT) regulations, Sage Metering will not accept delivery of equipment that has been contaminated without written evidence of decontamination, and has instituted the following Return/Repair conditions. Strict adherence to these conditions is required. Returned equipment that does not conform to the requirements listed below will not be processed. If Sage Metering finds evidence of contamination, we may, at our option, have the unit returned at your expense. For your reference, the requirements for packaging and labeling hazardous substances are listed in DOT regulations 49 CFR 172, 178, and 179.

1. The equipment must be completely cleaned and decontaminated prior to shipment to Sage Metering. This decontamination includes the sensor, probe, electronics and enclosures internally and externally. All packaging must be clean and free from contamination.
2. A Material Safety Data Sheet (MSDS) is required for all process fluids and gases that have been in contact with the equipment. This includes fluids or gases used in cleaning the equipment. A Decontamination Statement is also required for each meter returned using a different gas or fluid. Both the MSDS and the Decontamination Statement are to be attached to the OUTSIDE of the shipping container. If both documents are not attached, you will be called, and the equipment sent back to you at your expense.
3. The decontamination Statement must include the following required information
  - A. A list of all chemicals and process fluids used in the equipment, including decontamination fluids or gases.
  - B. The model and serial number of the equipment being returned.
  - C. A company officer or other authorized person’s signature on the statement.

### Return Shipping Address:

ATTENTION: \_\_\_\_\_

Sage Metering, Inc.  
8 Harris Court, Building D1  
Monterey, CA 93940

All shipments should be sent Freight Prepaid. Collect shipment may be refused or the freight costs may be billed back as part of the service.

## RETURN MATERIAL AUTHORIZATION

You may pre-mail your purchase order to: [service@sagemetering.com](mailto:service@sagemetering.com)  
Or fax directly to Fax # 1-831-655-4965

RMA # \_\_\_\_\_

Date \_\_\_\_\_

### RETURN CUSTOMER INFORMATION

Customer's Name \_\_\_\_\_ Fax # \_\_\_\_\_

Customer's Contact Name \_\_\_\_\_ Phone # \_\_\_\_\_

Email Address \_\_\_\_\_

### CUSTOMER'S RETURN ADDRESS

Bill To: \_\_\_\_\_ Ship To: \_\_\_\_\_

Street: \_\_\_\_\_ Street: \_\_\_\_\_

City: \_\_\_\_\_ City: \_\_\_\_\_

State: \_\_\_\_\_ Postal Code: \_\_\_\_\_ State: \_\_\_\_\_ Postal Code: \_\_\_\_\_

Country: \_\_\_\_\_ Country: \_\_\_\_\_

### CUSTOMER'S SHIPPING ACCOUNT NUMBER Check type of account

UPS \_\_\_\_\_ FedEx \_\_\_\_\_ DHL \_\_\_\_\_ Other \_\_\_\_\_ ACCOUNT # \_\_\_\_\_

### RETURN PRODUCT INFORMATION

Model No. \_\_\_\_\_ Serial No(s). \_\_\_\_\_

FLOW: MIN \_\_\_\_\_ NORMAL \_\_\_\_\_ MAX \_\_\_\_\_

TEMP: MIN \_\_\_\_\_ NORMAL \_\_\_\_\_ MAX \_\_\_\_\_

PRESSURE: MIN \_\_\_\_\_ NORMAL \_\_\_\_\_ MAX \_\_\_\_\_

PIPE SIZE/DUCT: \_\_\_\_\_ GAS: \_\_\_\_\_ OTHER: (special mix) \_\_\_\_\_

REASON THE METER(S) IS BEING RETURNED AND DESCRIPTION OF SYMPTOMS:

\_\_\_\_\_

\_\_\_\_\_

\_\_\_\_\_

\_\_\_\_\_

*(All non-warranty repairs could be subject to a minimum evaluation charge)*

Sage Metering Technical Contact \_\_\_\_\_

**All equipment must be clean and free of any contamination.** All "contaminated" equipment will be subject to additional cleaning fee and delays in processing.

Take special care when packaging your meter for return to the factory. The sensor in particular may easily be damaged if not prevented from shifting around within the package and if the sensor itself is not covered to keep it from contacting other package contents. Any damage resulting from improper packaging is the responsibility of the shipper.

**GENERAL TERMS AND CONDITIONS:** Detailed General Terms and Conditions can be found on the Sage website ([www.sagemetering.com](http://www.sagemetering.com)) on a link "General Terms" on the Footer of any page on the website.

## SAGE METERING, INC.

8 Harris Court, Building D-1 / Monterey, California 93940

PHONE: 831-242-2030 / FAX: 831-655-4965

# Section

**E**

**MODBUS**



## Modbus Register Listing

UINT32		IEEE Float		SCALED INT32*		Reg Description
Reg Offset	Reg Offset	Type	Reg Offset	Type		
256		UINT8				format flag
256		UINT8				modbus_unit_id
257		UINT8				output mode sel
257		UINT8				fix_pt selection
257		UINT1				bRun
257		UINT1				bTotal
257		UINT1				bEEProm
257		UINT1				bReset
257		UINT1				bLeadEn
257		UINT1				bDAClo
257		UINT1				bDACHi
	514	FLOAT	770	LONG		CAL_VAL
	516	FLOAT	772	LONG		K-FACTOR
	518	FLOAT	774	LONG		VREF
	520	FLOAT	776	LONG		LOAD-RES
TEMP	522	FLOAT	778	LONG		COEFF A
TEMP	524	FLOAT	780	LONG		COEFF B
TEMP	526	FLOAT	782	LONG		COEFF C
TEMP	528	FLOAT	784	LONG		COEFF D
	530	FLOAT	786	LONG		DISP A
	532	FLOAT	788	LONG		DISP B
	534	FLOAT	790	LONG		DISP C
	536	FLOAT	792	LONG		DISP D
FLOW	538	FLOAT	794	LONG		COEFF A
FLOW	540	FLOAT	796	LONG		COEFF B
FLOW	542	FLOAT	798	LONG		COEFF C
FLOW	544	FLOAT	800	LONG		COEFF D
FLOW	546	FLOAT	802	LONG		COEFF E
FLOW	548	FLOAT	804	LONG		COEFF F

UINT32		IEEE Float		SCALED INT32*		Reg Description
Reg Offset	Reg Offset	Type	Reg Offset	Type		
	550	FLOAT	806			iir filter coeff
	552	FLOAT	808			flow_min
	554	FLOAT	810			flow_max
	556	FLOAT	812			PULSE COUNT
	558	FLOAT	814			temp_max
302		UINT16				dac1_min
304		UINT16				dac1_max
306		UINT32				serial number
308		ASCII				RATE string
310		ASCII				TOTAL string
312		UINT32				current totalizer
314		UINT32				ADC0
316		UINT32				ADC1
318		UINT32				ADC2
320		UINT32				ADC3
	578	FLOAT	834	LONG		current flow
	580	FLOAT	836	LONG		current temp
	582	FLOAT	838	LONG		rtd_mWatts
	584	FLOAT	840	LONG		rtd_res
	586	FLOAT	842	LONG		ref_res_r
	588	FLOAT	844	LONG		ref_res_d
	590	FLOAT	846	LONG		dac_smooth
	592	FLOAT	848	LONG		lead
	594	FLOAT	850	LONG		oheat
	596	FLOAT	852	LONG		bv
	598	FLOAT	854	LONG		fv
	600	FLOAT	856	LONG		tv
	602	FLOAT	858	LONG		lv

\*SCALED INT32 register contents form INT32 values by multiplying the IEEE FLOAT x 1000  
ex. FLOAT -> 112.768 = SCALED INT32 -> 112768

## Sage Metering Modbus Protocol

Sage Rio Meters support communication with other devices via MODBUS® protocol using RTU transmission mode. The Modbus protocol defines a message structure that controllers will recognize and use, regardless of the type of networks over which they communicate. It establishes a common format for the layout and contents of message fields.

Transactions use a master-slave technique, in which only one device (the master) can initiate transactions (called queries). The other devices (the slaves) respond by supplying the requested data to the master and by taking the action requested in the query. Sage Meters operate as slaves to other Modbus devices and default to 19200-8-E-1, however, the following modes may also be software selectable:

9600-8-N-1	(Baud-Bits-Parity-Stop)
9600-8-E-1	
9600-8-O-1	
19200-8-N-1 <sup>1</sup>	
19200-8-E-1	(Default)
19200-8-O-1	

### MESSAGE FRAMING

Messages start with a silent interval of at least 3.5 character times followed by 4 fields and then followed by another silent interval of at least 3.5 character times. The first field contains the device address. The second field contains the function code. The third field contains the data and byte counts. The fourth field contains the CRC value.

<sup>1</sup> Parity on the Wireless Devices manufactured by Obvius is "None" rather than "Even". The Sage default is 19200-8-E-1. Change to 19200-8-N-1 for the Obvius Modhoppers and related wireless devices.

### ADDRESS FIELD

The address field contains one byte. Sage Rio Meters will transmit response packets to addresses which are between 1 to 240 decimal (inclusive). Modbus packet writes may be sent to broadcast address 00, however the Rio will not reply with a response packet.

### FUNCTION CODE FIELD

The function code field contains one byte. See the section titled *Function Codes Supported by Sage Rio*.

### DATA FIELD

The data field contains four or more bytes. This information is used by the Meter to take the action defined by the function code, or to read or write data to one or many registers.

### CRC FIELD

The CRC-16 (cyclical redundancy check) field is two bytes, containing a 16-bit binary value. The CRC value is calculated by the transmitting device, which appends the CRC to the message. The receiving device recalculates a CRC during receipt of the message, and compares the calculated value to the actual value it received in the CRC field. If the two values are not equal, the message will be discarded.

## Function Codes Supported by SAGE Rio

### 03 (0X03) READ HOLDING REGISTERS

Identical operation as code 04 READ INPUT REGISTERS described below, except READ only.

### 04 (0X04) READ INPUT REGISTERS

Reads the binary contents of the specified register. This is READ/WRITE register. Sage Rio values are typically 32 bits wide (4 bytes) and contain a single IEEE754 floating point value. Modbus registers are 16 bits wide (2 bytes) so a minimum of 2 Modbus registers are required to transfer all floating point bits to the master. See section titled *Sage Floating Point Format*.

### Query

The query message specifies the starting register address and the quantity of registers to be read.

0x03 READ MULTIPLE HOLDING REGISTERS or  
0x04 READ MULTIPLE INPUT REGISTERS

-QUERY-	-RESPONSE-
SA – SLAVE ADDRESS	SA
04 – FUNC CODE	04
RH – REG ADDR HI	BC – # of data bytes to follow
RL – REG ADDR LO	DATA0
00 – # OF REGS HI	DATA1
CT – # OF REGS LO	DATA <sub>n</sub>
CH – CRC MSB	CH CRC MSB
CL – CRC LSB	CL CRC LSB

REG ADDR HI (RH) is set to:

- 01 for INTEGER access of integral values
- 02 for IEEE754 floating point
- 03 for Scaled (x1000) long integer of floating point value

REG ADDR LO (RL) is the starting address index into the register structure. See section titled Sage Register Index Values.

CT is the register count needed to transfer data. Typically this byte is set to 02 to request 1 full IEEE754 floating point value. (Modbus single registers are 16 bits wide, Sage floating point values are 32 bits wide.)

DATA0-DATA<sub>n</sub> are bytes in binary format returned from the slave device representing the contents of the selected register(s).

**NOTE:** values indicated with 0x prefix are in hexadecimal, otherwise in decimal notation.

## 16 (0x10) WRITE REGISTERS

Writes the binary contents of the specified register into the meter. Sage Rio values are typically 32 bits wide (4 bytes) and contain a single IEEE754 floating point value. Modbus registers are 16 bits wide (2 bytes) so a minimum of 2 Modbus registers are required to transfer all floating point bits into the meter. See section titled *Sage Floating Point Format*.

### Query

The query message specifies the starting register address and the quantity of registers to be written.

#### 16 (0x10) WRITE MULTIPLE REGISTERS

–QUERY–	–RESPONSE–
SA – SLAVE ADDRESS	SA
0x10 – FUNC CODE	0x10 – 16 FUNC CODE
RH – REG ADDR HI	RH – REG ADDR HI
RL – REG ADDR LO	RL – REG ADDR LO
00 – # OF REGS HI	00 – # REGS HI
CT – # OF REGS LO	CT – # REGS LO
BC – BYTES COUNT	CH – CRC MSB
DATA0	CL – CRC LSB
DATA1	
DATAn	
CH – CRC MSB	
CL – CRC LSB	

REG ADDR HI (RH) is set to:

- 01 for INTEGER access of integral values
- 02 for IEEE754 floating point
- 03 for Scaled (x1000) long integer of floating point value

REG ADDR LO (RL) is the starting address index into the register structure. See section titled *Sage Register Index Values*.

CT is the register count needed to transfer data. Typically this byte is set to 02 to request 1 full IEEE754 floating point value.

BC is the actual number of bytes that follow.

DATA0-DATAn are bytes in binary format transmitted to the slave device representing the contents of the selected register(s).

**NOTE: THIS PAGE APPLIES TO REV. 1.81–1.83**

### 17 (0x11) REPORT SLAVE IDENTIFICATION\*

This query requests from the specified slave address a detailed identification packet with a run status, and Sage Rio and firmware revision response. (Rio will not respond to broadcast slave address 00.)

#### Query

The query message specifies the slave address, function code, and CRC check words.

#### 17 (0x11) REPORT SLAVE ID

-QUERY-	-RESPONSE-
SA – SLAVE ADDRESS	SA
11 – FUNC CODE	11
CL – CRC LSB	BC – BYTES COUNT, 19
CH – CRC MSB	SD – SLAVE ID (DEVICE SPECIFIC), 0x5A
	RS – RUN STATUS INDICATOR, 0xFF
	ASCII Text – SAGE Rio v1.81x
	CH
	CL

#### Response

The Sage Rio will respond with an echo of the slave address and function code. The byte count will be 19 (0x13) to allow the master to account for all the remaining bytes that follow.

REPORT SLAVE ID Example: (Slave Address = 0x30 = 48, default)

Master Query → 30 11 D5 BC

Rio Response → 30 11 13 5A FF 53 61 67 65 20 50 72 69 6D 65 20  
76 31 2E 38 31 20 F1 2B

ASCII translation → Sage Rio v1.81

### ILLEGAL FUNCTION CODES\*

The Sage Rio will respond to other Modbus function codes not documented in this revision, these codes are considered unsupported by Sage Metering. Unsupported function codes will cause the Rio to reply with Modbus ILLEGAL FUNCTION status.

\*Not implemented in revision 1.80

## SAGE REGISTER INDEX VALUES

DATA TYPE	VALUE	SIZE	INDEX	ADDRESS DESCRIPTION
Byte	slave_ad	1 BYTE	1	Modbus Slave Address*
float	flow_rate;	1 IEEE754	578	actual flow rate
float	flow_temp;	1 IEEE754	580	process temperature
float	rtd_mWatts;	1 IEEE754	582	sensor power reading
float	rtd_res;	1 IEEE754	584	actual sensor probe resistance
float	ref_res_r;	1 IEEE754	586	actual temperature probe resistance
integ	totalizer;	1 uLONG	312	actual displayed total

\*NOTE: Sage Rio Meters are factory programmed with the MODBUS slave address = 48 (0x30). It may be extremely useful to be able to write to an unknown slave address with a simple broadcast command. Be sure only one Sage Rio is connected during any broadcast writes using slave address = 0.

Writing into unspecified registers (not defined above) can render the unit non-functional or overwrite factory calibration data yielding incorrect operation.

## EXAMPLE MODBUS PACKET

### Query

This packet will request of the addressed slave to respond by sending back the contents of registers 578 to 582 (inclusive). Three registers: flow rate through RTD mWatts in IEEE754 floating point format.

```
0x31 - SAGE Rio SLAVE ADDRESS (0x31 Hex = 49 Decimal default)
0x04 - READ INPUT REGS FUNCTION CODE
0x02 - STARTING REGISTER HI BYTE (0x01 = 256, 0x02 = 512, 0x03 = 768)
0x42 - STARTING REGISTER LO BYTE (512 + 66 = register access = 578)
0x00 - COUNT MSB (ALWAYS ZERO)
0x06 - COUNT OF ALL DESIRED REGISTERS
0xD5 - CRC HI BYTE
0x85 - CRC LO BYTE
```

## Sage Register Output Format

### INTEGER REPRESENTATION

Computer systems hosting a MODBUS network typically store integer values to represent non-fractional quantities.

All registers addressed above 256 (0x0100-0x1FF) will transfer 16 bit integral quantities in response to all master queries. MODBUS requires that the register count reflects each 16 bit registers transmitted to ensure that no bytes are missing in the transfer of integer quantities. (Note: Most Sage Rio registers are IEEE754 quantities; integer representations of these registers will require significant translation.)

### IEEE754 FLOATING POINT

Computer systems hosting a MODBUS network typically store single precision floating point data in the standard IEEE754 format.

All registers addressed above 512 (0x0200-0x02FF) will transfer full 32 bit single precision quantities in response to all master queries. MODBUS requires that two 16 bit registers are transmitted to ensure that no bytes are missing in the transmission of 32 bit quantities.

### SCALED DECIMAL REPRESENTATION

Computer systems hosting a MODBUS network may choose represent single precision floating point values as scaled long integers (32 bit values). The Sage Rio will convert floating point registers to integral units by multiplying the value by 1000.

Ex. Floating point value 1234.567 will be converted to integral value 1234567

All registers addressed above 768 (0x0300-0x03FF) will transfer full 32 bit scaled integer quantities in

response to all master queries. MODBUS requires that two 16 bit registers are transmitted to ensure that no bytes are missing in the transmission of 32 bit quantities.

For more information on the MODBUS protocol, see: <http://www.modbus.org/tech.php>

### SAGE ADDRESSER SOFTWARE

Addresser is a convenient software kit that includes Addresser software, as well as an optically isolated ULINX RS485 to USB converter. The Addresser is a READ/WRITE Program with drop-down menus for convenient user interface between your PC or laptop and the Modbus Terminals of the Sage Rio. Contact Sage for ordering information and instructions.

### SAGE ADDRESSER TECHNICAL ASSISTANCE

Visit our website at [www.sagemetering.com](http://www.sagemetering.com), select "Knowledge Base" and "Service Manuals & Guides" then select "PRO-PRM-080911 Website Addresser 3\_14" or "Modbus Poll Instructions".

## Sage Addresser Typical Printout (Version 3.14)

SMB Printout  
Serial# 50043

Units: SCFM Modbus:  
0x31

6/23/2011  
12:01:50 PM

Parameter	Decimal Data	Hex Format
Calib mW Val	44.91799	8433AC08
K-Factor	1.000000	7F000000
Lead Gain Val	0.992098	7E7DFA22
Flow Load Res	20.10000	8320CCCD
Temp Calib[A]	-3.07714	80C4F000
Temp Calib[B]	1.144714	7F128600
Temp Calib[C]	-0.00121	759F7000
Temp Calib[D]	0.000003	6C3F3400
Temp Disp Null	0.000000	00000000
Temp Disp Gain	1.000000	7F000000
Amp Null Val	-0.16634	7CAA56DE
Amp Gain Val	1.008498	7F011676
Flow Coeff[A]	-20.7094	83A5ACF2
Flow Coeff[B]	0.720296	7E38654E
Flow Coeff[C]	-0.00880	789033FC
Flow Coeff[D]	0.000067	710D75E4
Flow Coeff[E]	0.000000	00000000
Flow Coeff[F]	0.000000	00000000
Filtering	0.500000	7E000000
Min Flow/LFC	0.000000	00000000
Full Scale	1200.000	89160000
Min Temp	40.00000	84200000
Units/Pulse	100.0000	85480000
DAC1 Min	725.0000	000002D5
DAC1 Max	3674.000	00000E5A
Serial Number	50043.00	0000C37B
Flow Units	12964504	4D464353
Total Units	11790099	46464353
Output Config	8.000000	00000008
Pulse Dur	250.0000	000000FA

# Section

**G**

**HART**



## HART

HART communications are optionally provided on some versions of the Sage Rio Thermal Mass Flow Meter. HART is designated by the code "HART" in the model number.

NOTE: HART will only be available if the 4-20 mA output is externally powered. A minimum resistance of 250 ohms is required between the power supply and the flow meter.

## RIO DISPLAY

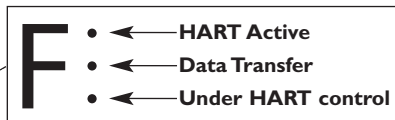
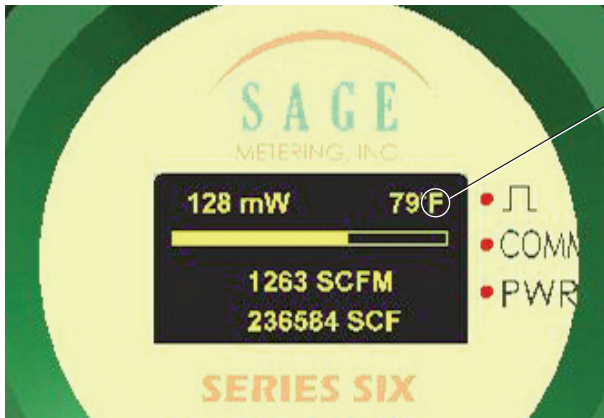

Next to the Temperature units of measurement (C or F) there are three pixel points. *See illustration above.*

- The top indicator is lit if HART is active.
- Middle indicator lit or flashes during active data transfer.
- The bottom is lit when the instrument is under HART control for manual settings or testing.

## HART WIRING

REFER TO PAGES 18 THROUGH 21 FOR WIRING DIAGRAMS. PLEASE REFER TO THE FOLLOWING FOR WIRING THE 4–20 mA OUTPUT ON UNITS WITH HART.

**Note:** Each unit with HART is supplied with a built-in SAGE ISOLATION circuit board.

### INTERNALLY POWERED 4–20 mA OUTPUT WITH HART AND PULSE

Built-in Isolation Circuit Board powers the 4–20 mA and Pulse Outputs with 15 VDC and provides Isolated Outputs (there is no option for externally powering the outputs).

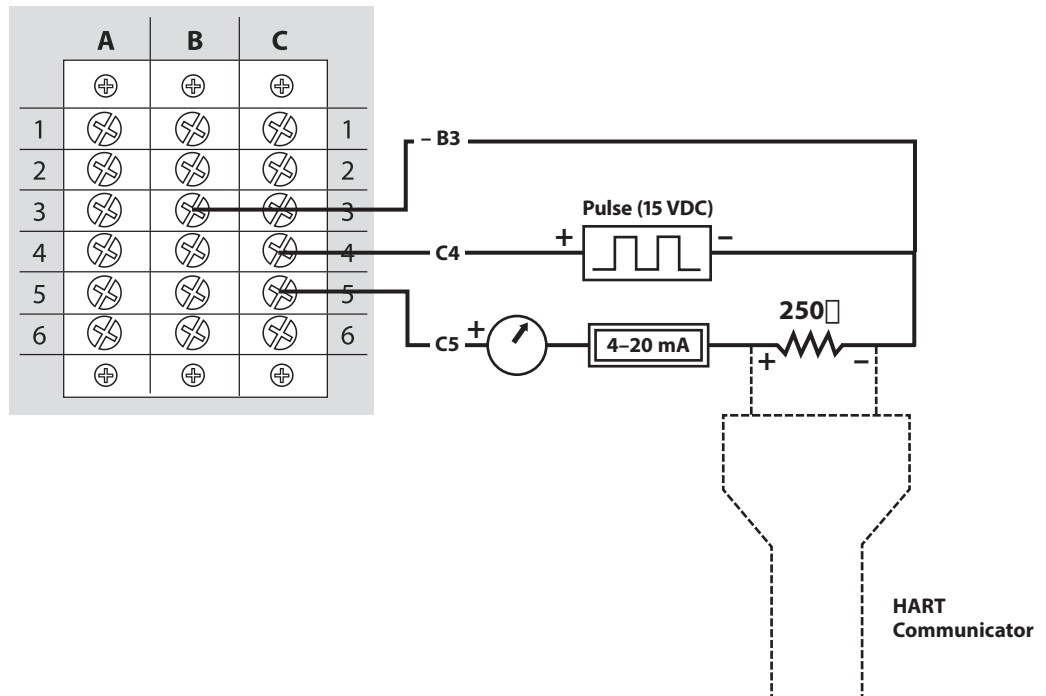

## HART Menu Tree

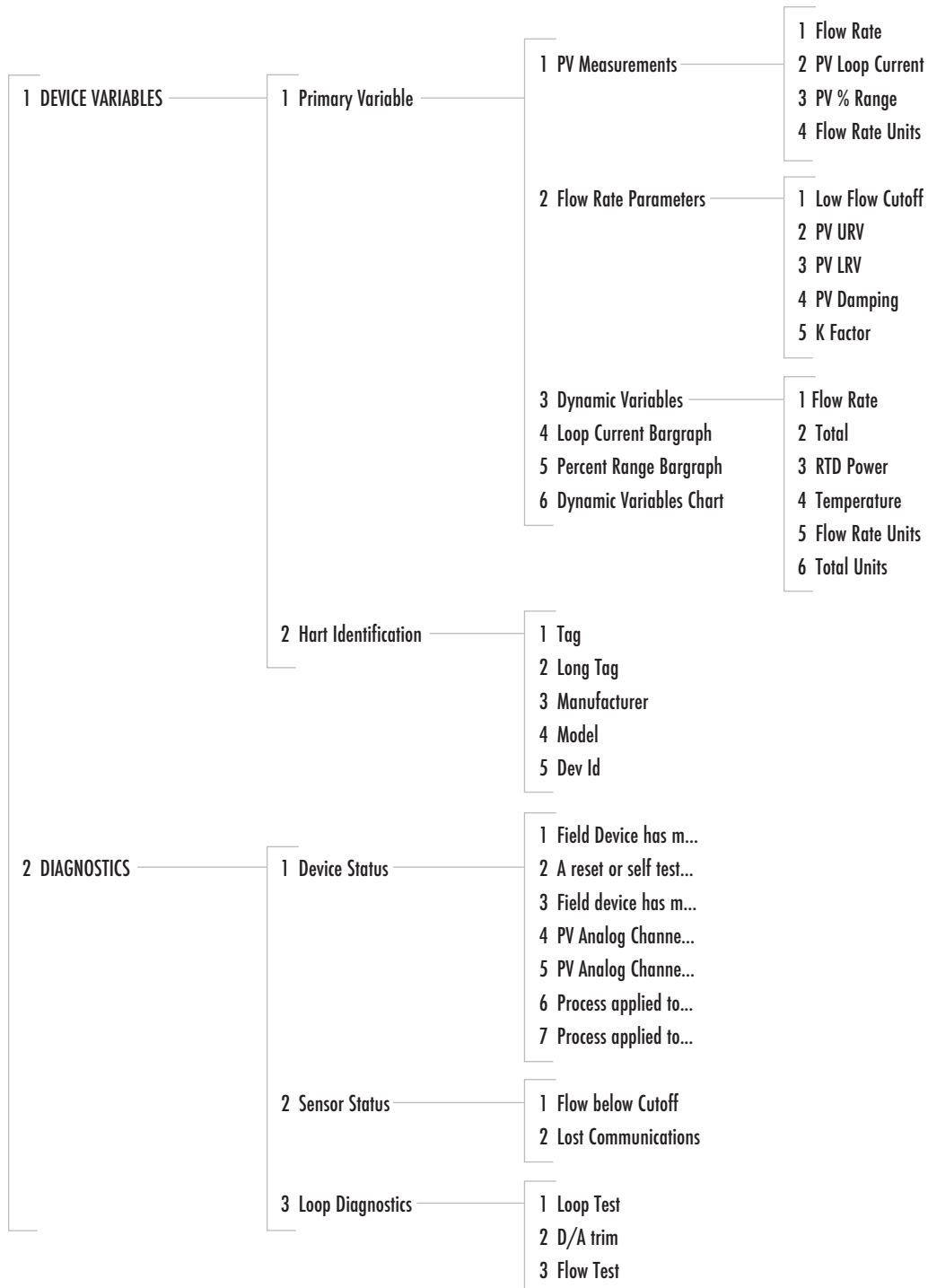

DEFAULT:  
 PV = Flow  
 SV = Temperature  
 TV = Total

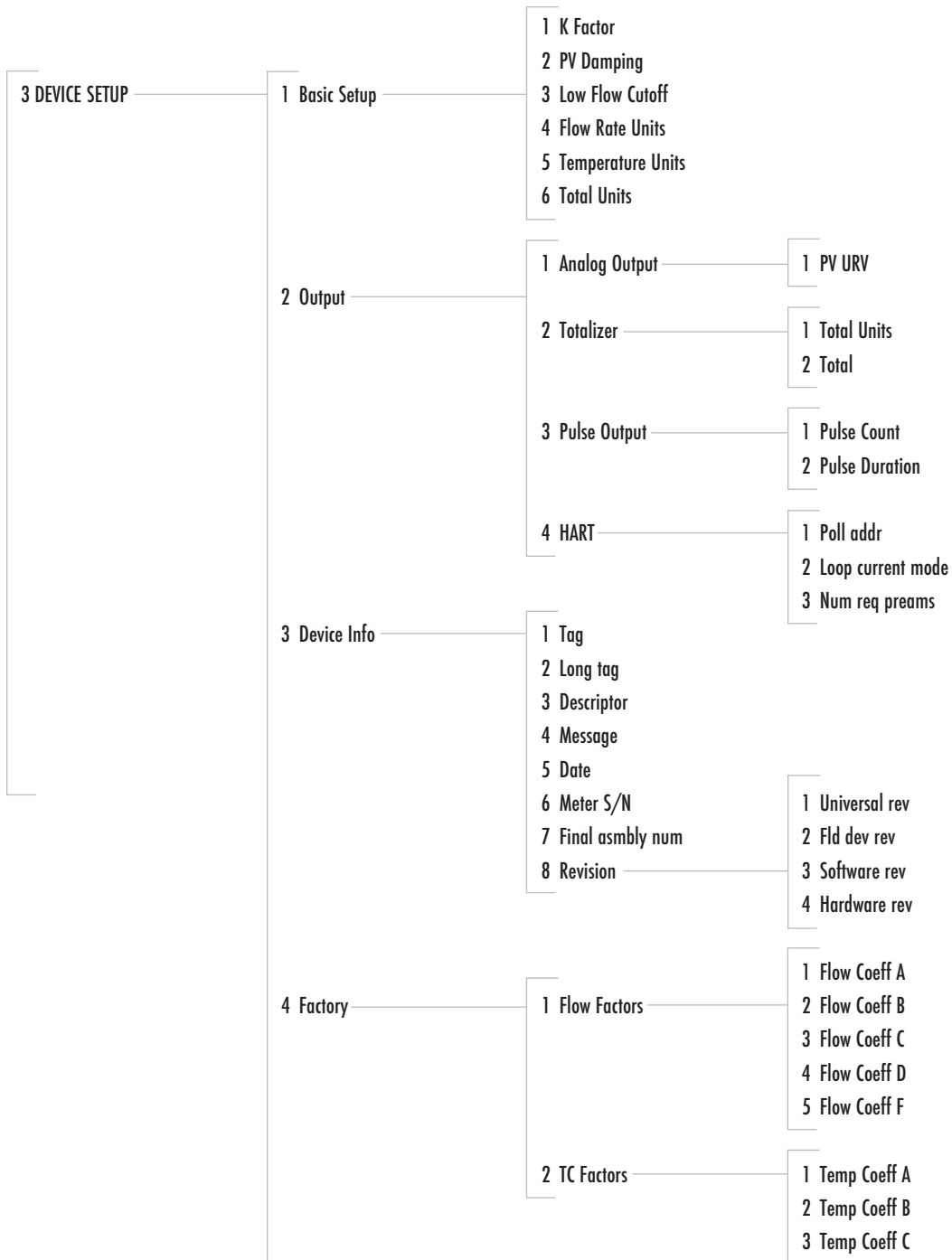

## HART

Following reviews the various parameters used in the HART menu structure and provides fast keys for accessing this information:

### PRIMARY VARIABLE - READ ONLY

Provides information regarding the Primary Variable (Flow)

#### PV Measurements

**Flow Rate** [Fast Key 1,1,1,1]

Actual measurement of the flow rate in the reference unit of measurement

**PV Loop Current** [Fast Key 1,1,1,2]

Analog value output ranging between 4 and 20 mA representing the flow rate. The 4 and 20 mA loop can be verified by using the Loop Test described below in the Diagnostic section [Fast Key 2,3,1].

**PV % of Range** [Fast Key 1,1,1,3]

Provides the value of the flow rate representing the % of range between the LRV (Lower Range Value) and the URV (Upper Range Value).

**Flow Rate Units** [Fast Key 1,1,1,4]

Units of measurement associated with the flow rate.

#### Flow Rate Parameters

**Low Flow Cutoff** [Fast Key 1,1,2,1]

Any measured flow rate below this value will be set to 0.

**PV URV** [Fast Key 1,1,2,2]

Upper Range Value of the Primary Variable.  
Represents the 20 mA value

**PV LRV** [Fast Key 1,1,2,3]

Lower Range Value of the Primary Variable.  
Represents the 4 mA value. Value is 0.

**PV Damping** [Fast Key 1,1,2,4]

Primary Variable Damping factor. Used to smooth out normal occurring fluctuations in the flow rate. Values range between .001 and .999 which represents no smoothing. Lower values increase damping.

**K Factor** [Fast Key 1,1,2,5]

K Factor is a linear adjustment factor which may be used to adjust the flow rate for various reasons requested by the user. Default is 1.

#### Dynamic Variables

**Flow Rate** [Fast Key 1,1,3,1]

Displays the current flow rate measured by the flow meter.

**Total** [Fast Key 1,1,3,2]

Displays the total flow measured by the instrument.

**RTD Power** [Fast Key 1,1,3,3]

Measurement of the power in mW corresponding to the measured flow rate. Useful for diagnostic purposes

**Temperature** [Fast Key 1,1,3,4]

Displays the gas temperature where the sensor is located

**Flow Rate Units** [Fast Key 1,1,3,5]

Units of measurement of the flow rate

**Total Units** [Fast Key 1,1,3,6]

Units of measurement of the total flow

**Loop Current Bargraph** [Fast Key 1,1,4]

Displays a graphic chart showing the mA output of the flow rate vs. time – Range between 4 and 20 mA

**Percent Range Bargraph** [Fast Key 1,1,5]

Displays a graphic chart showing the flow rate as a % of range between the LRV and URV

**Dynamic Variables Chart** [Fast Key 1,1,6]

Displays a graphic chart showing flow rate in selected units of measurement vs. time

#### HART IDENTIFICATION

**Tag** [Fast Key 1,2,1]

A Tag value entered by the user to identify the flow meter. Up to 8 digits in length

**Long Tag** [Fast Key 1,2,2]

A value entered by the user

**Manufacturer** [Fast Key 1,2,3]

The name of the Manufacturer of the flow meter. In this case it is Sage Metering

**Model** [Fast Key 1,2,4]

Manufacturer's model number of the flow meter.

**Device Id** [Fast Key 1,2,5]

Factory entered number which is unique for each instrument

**DIAGNOSTICS****Device Status** [Fast Key 2,1]

Will indicate any standard diagnostics message

**Sensor Status****Flow Below Cutoff** [Fast Key 2,2,1]

Diagnostics menu indicating that the measured flow rate is less than the low flow cutoff

**Loop Diagnostics****Loop Test** [Fast Key 2,3,1]

Permits the user to drive the mA output to a desired value.

**D/A Trim** [Fast Key 2,3,2]

Used to calibrate the 4-20 mA output from the flow meter to match the system loop.

**Flow Test** [Fast Key 2,3,3]

Permits user to enter a value for the RTD Power with the display showing expected flow rate based on original calibration. Useful diagnostics test to insure that the flow meter is matching the original calibration curve.

**DEVICE SETUP****Basic Setup****K Factor** [Fast Key 3,1,1]

Enter a K factor which will provide a linear adjustment of the flow rate. May be used to correct for different pipe size, varying gas composition, or installation effects which change the performance of the flow meter.

**PV Damping** [Fast Key 3,1,2]

Provides smoothing of normally occurring flow fluctuations. Value between 0.001 to 0.999; the lower the value providing greater smoothing (time averaging).

**Low Flow Cutoff** [Fast Key 3,1,3]

Enter a minimum value of the flow rate. Flow rates measured below this value will be shown as zero flow. Useful to disregard any false readings which might occur during a no flow condition

**Flow Rate Units** [Fast Key 3,1,4]

Units of measurement of the flow rate. This is a text entry. Any change in units of measurement from original calibration must also apply a K factor

**Temperature Units** [Fast Key 3,1,5]

Displays the units of measurement of the gas temperature

**Total Units** [Fast Key 3,1,6]

Four digit entry. The first three digits will represent the units of measurements of total flow and the fourth digit will be "C" or "F" to identify units of measurement of the temperature reading.

**OUTPUT****Analog Output****PV URV** [Fast Key 3,2,1,1]

Enter the Upper Range Value for the Primary Variable (flow rate). The URV must be in the identified units of measurement and must be within the calibration range of the instrument. Consult Sage Metering if assistance is required.

**Totalizer****Total Units** [Fast Key 3,2,2,1]

Displays the units of measurement for the totalized value.

**Total** [Fast Key 3,2,2,2]

Displays the totalized value in the selected units of measurement.

**Pulse Output****Pulse Count** [Fast key 3,2,3,1]

Provides the number of units per pulse. Example will be a Pulse Count of 100 and units are set to SCF, then one pulse is equivalent to 100 SCF.

**Pulse Duration** [Fast Key 3,2,3,2]**HART****Poll Address** [Fast Key 3,2,4,1]

Used multi drop installations to identify an individual instrument. Values can range between 1 and 15. If used in a multi drop configuration the 4-20mA output will be set to 4 mA. The default setting is a Poll Address = 0 with the 4-20 mA analog signal operational.

**Loop Current Mode** [Fast Key 3,2,4,2]

Allows the user to select whether the loop current is enabled (active) or disabled (fixed at 4mA) regardless of the poll address setting.

**Number of Request Preambles** [Fast Key 3,2,4,3]

Required HART command – indicates the number of preambles required by the instrument for HART communication.

**DEVICE INFORMATION****Tag** [Fast Key 3,3,1]

Enter a 8 digit tag which can be used to identify the instrument

**Long Tag** [Fast Key 3,3,2]

Enter up to a 32 digit tag which can be used for any purpose desired by the user.

**Descriptor** [Fast Key 3,3,3]

A 16 character entry which can be used for additional identification of the instrument.

**Message** [Fast Key 3,3,4]

A 32 character entry which can be used for identification or other purposes.

**Date** [Fast Key 3,3,5]

Enter date code; often used to enter last date a configuration change had been made.

**Meter S/N** [Fast Key 3,3,6]

Factory entry of the serial number of the instrument

**Final Assembly num** [Fast Key 3,3,7]

User entered identification which may be used for future reference

**REVISIONS:**

- **Universal Revision Number** [Fast key 3,3,8,1]  
Identifies the HART specification used in the design of the instrument.
- **Field Device Revision Number** [Fast Key 3,3,8,2]  
Provides the instrument revision for HART compatibility
- **Software Revision Level** [Fast Key 3,3,8,3]  
Provides the software revision used by the instrument
- **Hardware Revision Level** [Fast Key 3,3,8,4]  
Provides the Hardware revision level of the instrument

**FACTORY****Flow Factors and TC Factors**

Displays factory entered calibration values for the instrument



# Section

**G**

**APPENDIX**



## Sage Rio Service Department “Dongle”

Although virtually any setting on Sage Rio can be changed by users who have Modbus® capability via Terminals C1, C2 and C3 (see page 20), not all customers have that capability to communicate with the Prime using its Modbus Compliant RS485 Communications. However, users do not need to have a Modbus host or any special skill, since they can also change selected configurations in the field by using the patent pending Sage “Dongle”.

The Sage Rio device known as a “Dongle”, was developed to facilitate making very basic changes on Sage Rio Flow Meter settings in the field. Simply contact the Sage Service Department and specify your requirement (such as the new Full Scale, new Pipe Area, etc), and the device will be programmed at Sage and sent directly to you within a few days (there is a slight fee for this service). The patent-pending Dongle can also be configured as a Reset Totalizer device (i.e. it can be used repeatedly, with any Sage Rio to easily reset the Totalizer). The Dongle can also be programmed to change Engineering Units, Filter Response and numerous other parameters.

Dongles come with a convenient well marked cable that is connected to the RS485 terminals. First disconnect the power. Then remove the rear cover and connect the Dongle wires to terminals C1, C2 & C3. There is a button on the Dongle, push this button within the first 10 seconds as soon as you power up the meter. An LED will illuminate, and within 3 seconds the light will go out signaling that the data transfer is complete.<sup>1</sup> Remove the Dongle, close the cover, and you will notice that the new settings have been uploaded (or in the case of a Totalizer-Reset Dongle, you will notice that the Totalizer has zeroed).



<sup>1</sup> If the light does not go out, it will be necessary to repeat procedure. Remove finger for a few seconds and then push button again.

## Correction Factors For Variation From Original Digester Gas Calibration

Sage can calibrate for any Digester Gas, Bio Gas or Landfill Gas Mix. However, it may be helpful to have correction factors for a typical calibration, in the event that the composition changes after delivery. The following examples assume that the initial calibration was set up for 60% CH<sub>4</sub> and 40% CO<sub>2</sub>.

- a) 65% CH<sub>4</sub> and 35% CO<sub>2</sub>: Multiply reading by 0.982 to correct it for new composition
  - b) 70% CH<sub>4</sub> and 30% CO<sub>2</sub>: Multiply reading by 0.965 to correct it for new composition
  - c) 55% CH<sub>4</sub> and 45% CO<sub>2</sub>: Multiply reading by 1.0185 to correct it for new composition
- For smaller changes, the corrections are linear in between
- d) Also, if 100% saturated with H<sub>2</sub>O vapor (non-condensing), multiply readings by 1.042
  - e) If 50% saturated with water, multiply reading by 1.021  
(Water vapor correction is linear in between)

Also, use the 45 degree mounting method in order to avoid droplets from hitting the sensor and causing spikes (see above right)

## Installations Where Pipe Condensation May Develop

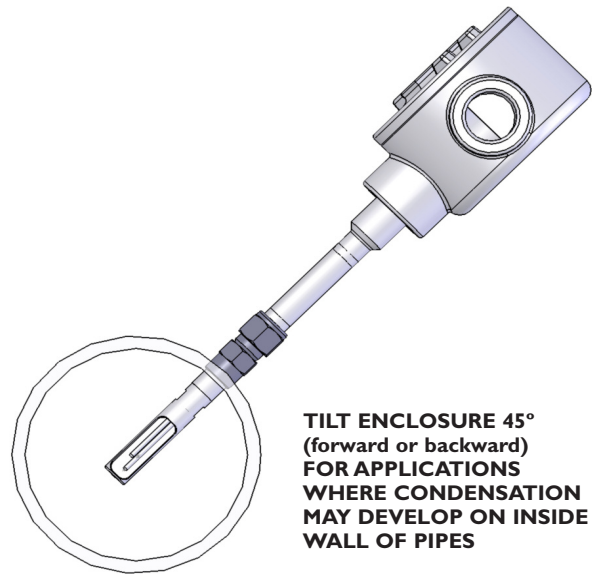

**TILT ENCLOSURE 45°  
(forward or backward)  
FOR APPLICATIONS  
WHERE CONDENSATION  
MAY DEVELOP ON INSIDE  
WALL OF PIPES**

## J-Box and Upstream Orientation

**NOTE:**  
ATEX approved cable  
gland/strain relief  
provided with unit.

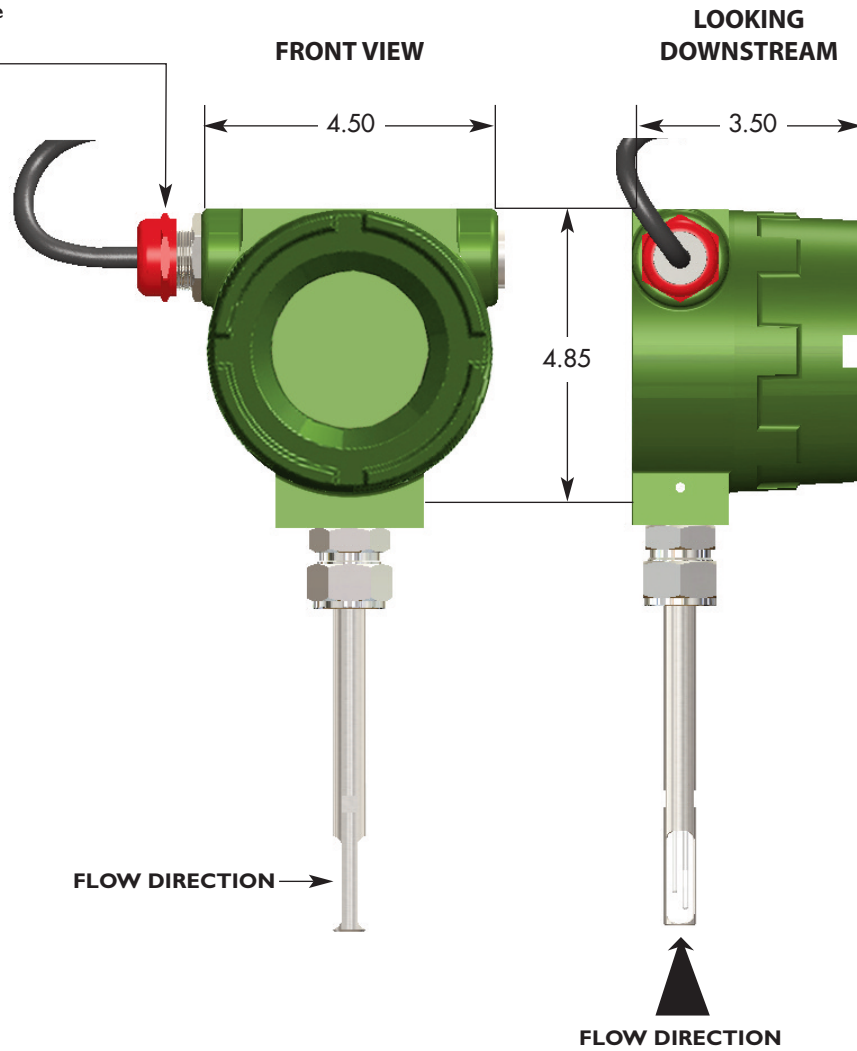

## What is a Thermal Mass Flow Meter?

- What is a Thermal Mass Flow Meter? It is a meter that directly measures the gas mass flow based on the principle of conductive and convective heat transfer.
- All Meters have probes (Insertion Style) or Flow Bodies (In-Line Style) that support a pair of sensors, which are in contact with the gas.
- The sensors are RTDs, which are resistance temperature detectors. They consist of highly stable reference-grade platinum windings. In fact, we use the same material that is used as Platinum Resistance Standards at the NIST.
- The RTDs are clad in a protective 316 SS or Hastelloy C sheath for industrial environments.
- One of the RTDs [See Diagram below] is self-heated by the circuitry and serves as the flow sensor. The other RTD acts as a reference sensor, and measures the gas temperature. Essentially it is used for temperature compensation.
- The Sage proprietary sensor drive circuitry maintains a constant overheat between the flow sensor and the reference sensor. As gas flows by the heated sensor (flow sensor), the molecules of flowing gas carry heat away from this sensor, and the sensor cools down as it loses energy. The circuit equilibrium is disturbed, and momentarily the temperature difference between the heated sensor and the reference sensor has changed. The circuit will automatically (within 1 second) replace this lost energy by heating up the flow sensor so the overheat temperature is restored.
- The current required to maintain this overheat represents the mass flow signal. There is no need for external temperature or pressure devices.

